

The **SOLARBOTICS**

Sumovore[®] Mini-Sumo

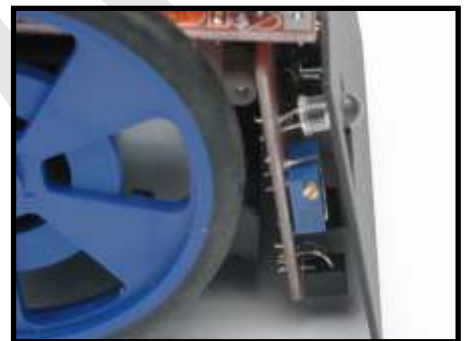
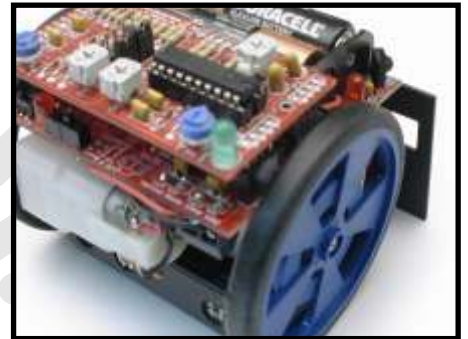
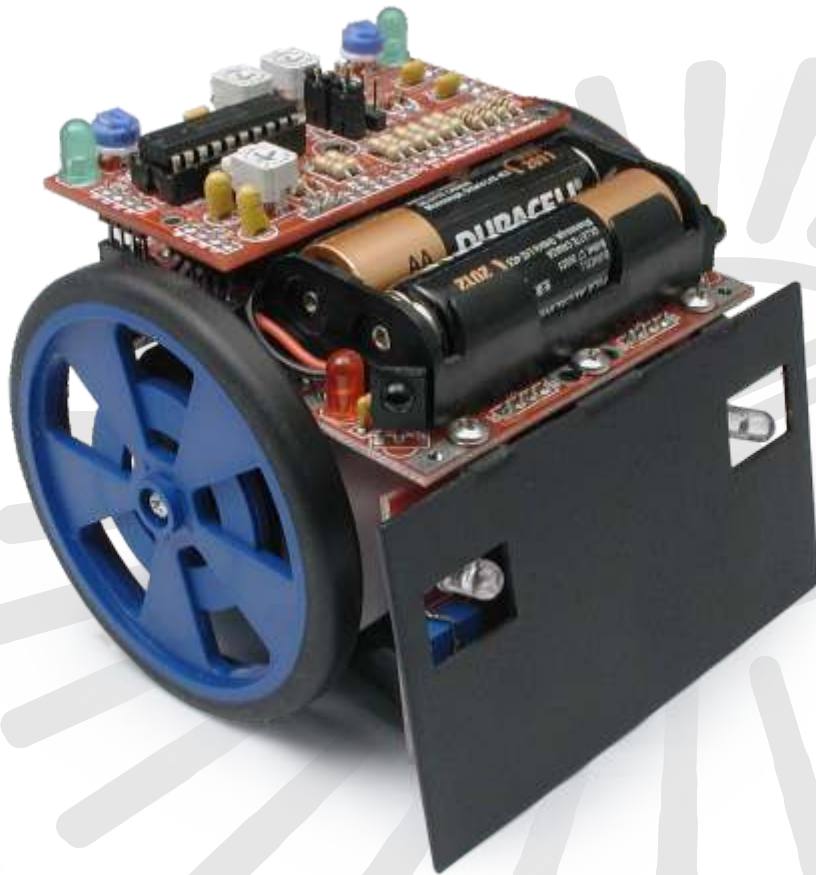

Using superior components and engineering, the Sumovore has won many mini-sumo contests world-wide! Be stronger and smarter in the ring using the most flexible, most powerful mini-sumo robot kit available.

Using 6 sensors (with space for more for you to install), the Sumovore tracks opposing robots while staying in the sumo ring!

Also use your Sumovore as a line-follower, or add your own custom programs by using one of the modular microcontroller brainboards (not included).



Skill Level:
Intermediate/Advanced
(Soldering Req'd)





The Solarbotics Sumovore

Introduction



The Japanese brought robot sumo wrestling to North America some years ago, and then they promptly proceeded to mop the floor with our robots. The Japanese take their sumo wrestling very seriously, and they applied the same enthusiasm to the robotic counterpart. All who saw these sumo robots compete were taken by the elegant simplicity of the contest, and many joined in to make "Japanese Standards" robot sumo happen in the Western world.

As fun as it was to watch the contests, the size and resources required to build these robots to Japanese standards held many others back from joining in with the fun. This is when Bill Harrison developed a new class of robot sumo - the Mini-Sumo. Mini-sumo was designed to be half the size, 1/6th the weight, fought on a ring half the diameter and considerably less expensive to build than a standard class sumo. It proved to be such a popular event, that now mini-sumo robot competitions run all around the world!

Solarbotics has now joined the fun by bringing the Sumovore kit to the ring! We have the unique resources to combine modular design, inexpensive components, and clever electronics into an affordable package that lets you have a shot at being Yokozuna (Grand Champion) at your next robot sumo competition.

Here's what the Sumovore has to offer:

- Fully conforms to mini-sumo competition requirements
- 9V operation (6 AA cells)
- Powerful 143:1 gear motors (not servos)
- Up to FIVE front edge sensors
- Two active IR opponent detection sensors
- Steel baseplate for sturdy construction
- Modular electronics spread between a mainboard and two daughterboards
- Included advanced-behaviour discrete brain module (easily swapped out)
- Discrete Brain "Sumo-Dance" inhibitor (5 seconds of no change in opponent detection, Sumovore charges forward)
- Discrete Brain "Edge-Ram" inhibitor (direct-on edge charge forces a backup/turn right behaviour rather than repeated edge charges)
- Powder-coated steel (not aluminum) front plate in multiple colours
- Custom-made 2-5/8" diameter wheels in multiple colours
- Full schematics included for custom hacking
- One optional rear IR detection sensor runnable in active or passive modes
- Optional easily-activated built-in line-follower mode
- Optional Basic Stamp II / Stamp Stack brain module
- Optional PIC 16F67A7 brainboard with breadboard space
- Optional Atmel Mega8L brainboard with breadboard space

Being the result of over 20 prototypes and 500 man-hours of development, the Sumovore is faster, cheaper, better performing and heavier than any other stock mini-sumo kit. We are sure you will have a good time building and competing your robot, so warm up that soldering iron - it's time to build!

Disclaimer of Liability & Notice of Copyright and Trademark

Solarbotics® Ltd. is not responsible for any special, incidental, or consequential damages resulting from any breach of warranty, or under any legal theory, including lost profits, downtime, good-will, damage to or replacement of equipment or property, and any costs or recovering of any material or goods associated with the assembly or use of this product. Solarbotics® Ltd. values constructive feedback, raspberry-strawberry-chocolate milkshakes, and smart friendly dogs. Solarbotics® Ltd. reserves the right to make substitutions and changes to this product without prior notice.

"SOLARBOTICS" is a trademark of Solarbotics® Ltd. Reg. CIPO / USPTO.

"SUMOVORE" is copyright, Solarbotics® Ltd. 2003



The Solarbotics Sumovore

Parts List



Body Components

- 1 - PCB (3 PCB's in one, will require separating along scored lines)
- 2 - Gear Motors
- 2 - GMPW - Gear Motor Wheels
- 4 - Traction Bands
- 1 - Dual AA Battery Holder
- 1 - Quad AA Battery Holder
- 1 - Front Plate
- 1 - Steel Baseplate
- 3 - #2 x 1/8" Nylon Spacers (for mounting / spacing PCB)
- 3 - #2 x 3/8" long thread-forming screw (for mounting / spacing PCB)
- 2 - #2 x 1-1/4" long thread-forming screw (for mounting battery pack)
- 4 - #4-20 x 1/2" long thread-forming screw (for mounting motors)
- 3 - #4-40 x 1/4" thread rolling screw (in main board components bag)
- 4 - #2-56 Sheet metal screw (in main board components bag)
- 6 - AA Batteries Required

Main Board Components

- 2 - 1M Resistor (Brown/Black/Green)
- 3 - 1k Resistor (Brown/Black/Red)
- 1 - 74AC14
- 1 - 14 Pin DIP Carrier
- 1 - L293D
- 1 - 16 Pin DIP Carrier
- 2 - PNA4602 - IR Detector
- 1 - 2937 Vreg - Voltage Regulator
- 1 - SWT1 - Power Switch
- 1 - SWT3 - Motor Enable Switch
- 3 - Red LEDs
- 8 - 0.1 μ F Capacitor (labeled '104')
- 2 - 6.8 μ F Capacitor
- 1 - 1000 μ F Capacitor
- 2 - Two Wire Terminal Blocks
- 2 - 4 Pin Header
- 2 - 4 Socket Header
- 2 - 8 Socket Header

Edge/IR Board Components

- 1 - 100k Resistor (Brown/Black/Yellow)
- 5 - 240 Ohm Resistor (Red/Yellow/Brown)
- 1 - 3k Resistor (Orange/Black/Red)
- 2 - 47 Ohm Resistors (Yellow/Purple/Black)
- 1 - LM555
- 2 - IR LEDs
- 1 - 20k Multi-turn Trimpot
- 1 - 2N2222 Transistor
- 2 - 0.001 μ F Capacitor (labeled '102')
- 2 - Molex 90 Degree Edge Connectors
- 4 - QRD1114 - Edge Detectors

Discrete Brainboard Components

- 4 - 1k Resistors (Brown/Black/Red)
- 8 - 47k Resistors (Yellow/Purple/Orange)
- 2 - 10k Single-turn Trimpot
- 1 - 74HCT240
- 1 - 20 Pin DIP Carrier
- 9 - 1N914 Diodes
- 4 - 0.47 μ F Capacitors (labeled '474')
- 2 - 6.8 μ F Capacitors
- 2 - Green LEDs
- 1 - SWT10 - 5 Second Timer Reset
- 2 - 4 Pin Header
- 2 - 8 Pin Header
- 4 - 2 Pin Jumper
- 2 - 2 Pin Shunt
- 1 - 470k Resistor (Yellow/Purple/Yellow)
- 3 - 2M Single-turn Trimpot

Tools Required:

- Soldering equipment (soldering iron, solder, sponge)
- Side cutters (wire snips, or nail-cutters will do)
- Wire strippers
- Needle Nose pliers
- Medium Phillips Screwdriver
- Small flat-head screwdriver (for tuning)
- Drill & 1/8" drill bit
- Sharp knife or angled snips
- #1 Phillips Screwdriver with good handle - you'll be twisting some screws!

Optional:

- Superglue or Hot-Glue gun
- Alcohol (or other non-residue cleaner)

We strongly suggest you inventory the parts in your kit to make sure you have all the parts listed. In the very unlikely occurrence that anything is missing, contact Solarbotics Ltd. for replacement parts information.



The Solarbotics Sumovore

Soldering Tutorial



Soldering! If you have never soldered before, it could be an intimidating concept. After all, you're being asked to take a scalding-hot piece of metal, and use it to melt metal onto delicate electronic components!

It is actually a pretty straight-forward process. We've taught 8-year old kids to solder (with supervision), so there's no reason why you can't wrap your head around this skill.

The trick is heat. Heat is good. Too often, new students are scared by the concept of all this heat in a small space. Well, what is really hot to you and me (the soldering iron), is actually just a sunny day at the beach for the components.

A successful solder connection can almost be guaranteed if you remember you are heating two pieces of metal, not just one. Here's the basic procedure:

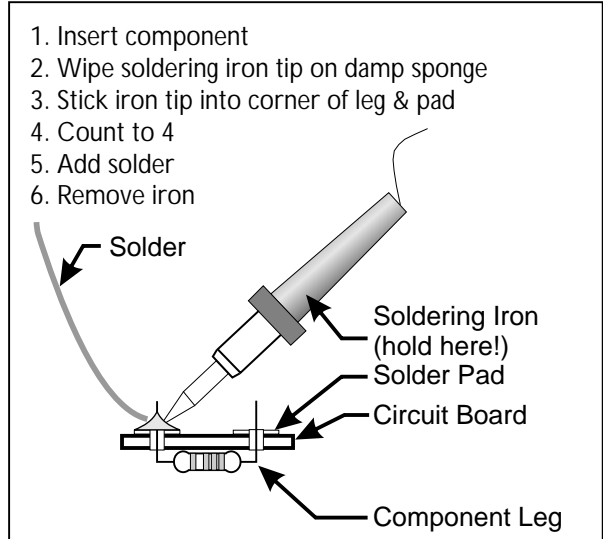

- 1) Put the component leg through the solder pad hole (snugged up close)
- 2) Wipe off the tip of the soldering iron on a damp sponge so it's shiny and clean. It transfers heat better when it's clean.
- 2) Holding the soldering iron like a pencil (not at the tip! Hot metal, remember?), jam the tip into the corner where the leg comes through the hole. This means the soldering iron tip is heating both the leg and the solder pad.
- 3) Count to 4. This heats up the parts.
- 4) While keeping the soldering iron in place, add solder to the other side of the leg. At this point, both the leg and pad will be hot enough that they will melt the solder into a nice connection. You'll probably notice some yellow or clear goop appear when you solder. Don't worry, this is flux, and it is in the solder to help make a good, clean connection.

Do NOT treat the soldering iron like a brush. That is, DON'T melt solder to the tip, and then try to smear it onto the connection. You're an electronics enthusiast, not a painter!

If you mess up, don't worry. You can reheat the solder and bang it loose with a quick snap onto a pad of paper (please use eye protection at all times). If you get two solder pads fused together, use the soldering iron like a pen, and "draw" a line between the pads. The solder will remelt, and flow off to the sides.

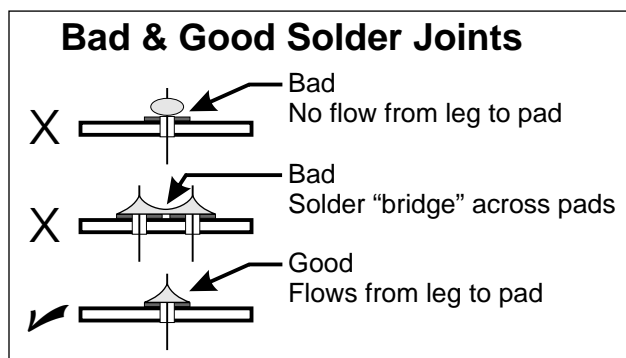

The final check for any solder joint is the "wiggle test". Firmly grip each component and gently rock it side-to-side. Any movement of the component legs on the other side of the board means the joint isn't firm, no matter how good it looks. Reheat and apply more solder to the joint.

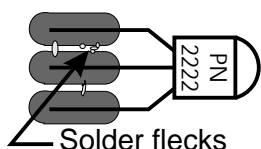

One of the most common errors is to accidentally "bridge" the pads between components. Make sure that there aren't any tiny flecks of solder or wire between the pads.



The Solarbotics Sumovore



Building the Mainboard Electronics - 1

Let's bring the Sumovore to life! We're going to start with the mainboard, as it is both the electronic and mechanical core of the whole robot. Before starting, read the whole procedure. Yes, really! Building it isn't the contest, so take your time here and do it right. There's some tricky parts, so be prepared.

When you've read this section, snap your PCB apart (yes, it snaps apart), turn on your soldering iron, get your parts, and sit down in a comfy spot and get to work.

Steps 1-3: Installing R1-R4, Voltage Regulator

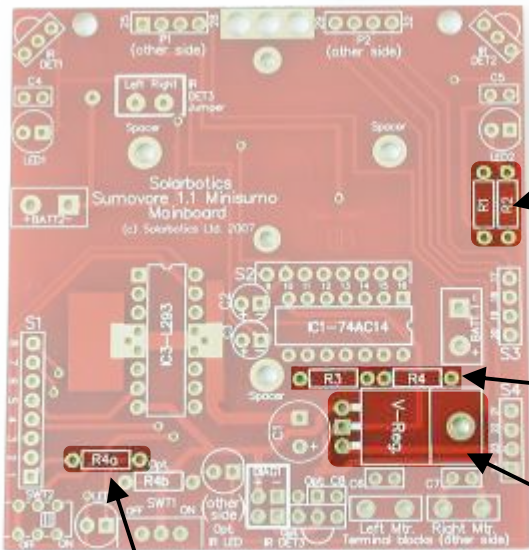

Step 1: 1k Resistors (x 2)

Step 1: R1, R2, R4a - 1k Resistors (Brn / Blk / Red)
Bend the resistor leads over, and insert them into positions R1, R2, and R4a. These resistors limit the power going through the 'LED1' and 'LED2' "opponent detected" indicators. R4a is for the power-indicator LED.

Step 2: 1M Resistors (x 2)

Step 2: R3, R4 1M Resistors (Brn / Blk / Grn)
Bend the resistor leads over, and insert them into positions 'R3' and 'R4'. These resistors help filter false signals that come from the IR detectors.

Step 1:
1k Resistor

Step 3: Voltage Reg.

Step 3: IC2 - LM2937 Voltage Regulator
Bend the legs down on the voltage regulator, and insert it face-up, flush to the PCB, next to R3 and R4 at position 'IC2'

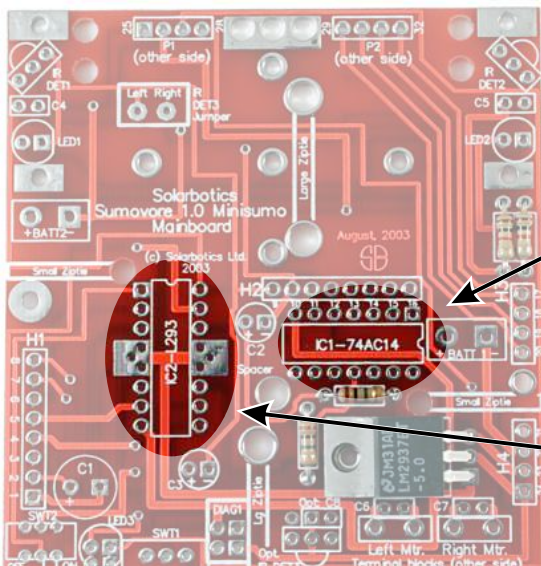

Step 4: 74AC14 Carrier (14 pins)

Step 4 & 5: Chip Carrier Installation

The whole reason for putting in chip carriers is so there's little fear of soldering a chip in backwards, or of frying a chip.

Note the little notch out of the front of the carrier - you want that to match the position of the notch on the shape of the IC picture on the PCB. This is so you'll know which way to put in the IC into the carrier later. Just because you can install a chip backwards, doesn't mean you should!

Step 5: L293 Carrier (16 pins)

Steps 4, 5: Installing 74AC14 and L293 chip carriers

Carriers, Resistors, and Voltage Regulator installed

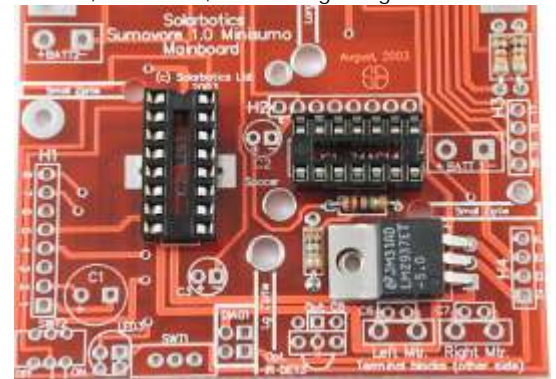

Note: One purpose of the chip carrier is so that you won't damage the chip while you're assembling the rest of the PCB. If you feel you're particularly accident-prone, add the chips to the sockets only just before adding the batteries for the first time!



The Solarbotics Sumovore



Building the Mainboard Electronics - 2

Step 6: Install ICs

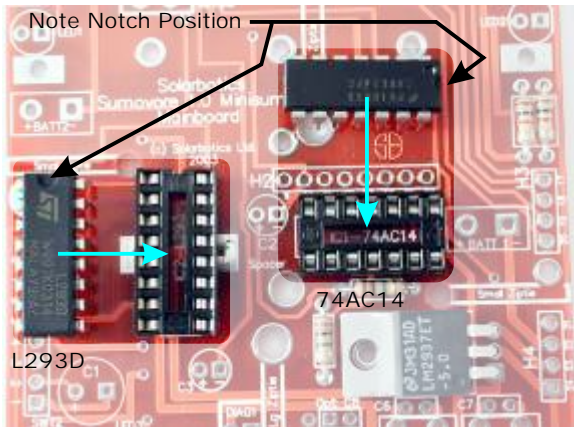

Step 6: Installing L293 and 74AC14 into carriers

Step 6: Installing the ICs into the Carriers

This part isn't hard, because if you mess it up, it's easily corrected. Simply note which side of each chip has the notch, and install each into the proper carriers. Confirm all legs go into the slots!

Note: You may have to gently bend the chip's legs inwards a bit to make them fit into the carrier!

The L293D is the chip that routes the actual power to the motors, so if you severely abuse your minisumo, you may need to replace it. This is very unlikely, especially since it has a feature called "thermal shutdown" which turns off the chip if it gets too hot.

The 74AC14 is used to condition the sensor signals so they make sense to the rest of the electronics in your minisumo, and is also part of the 5 second startup delay timer.

Step 7, 8, & 9: Capacitors C1-C3, C6, C7

Finish by inserting the 6.8µF tantalum capacitors in spots 'C2' and 'C3', again, noting polarity. The longer lead is the '+' side. You **MUST** get the polarity right with these capacitors! You risk blowing them up if they're installed backwards!

Next, install the can-like 1000µF 6.3V. Bend the leads over as shown, and insert into the 'C1' position.

Note: The striped side of the capacitor is negative; make sure the lead nearest the stripe (the shorter lead of the two) is going to the square pad.

Lastly, the 0.1µF (labeled '104') capacitors don't mind how they're installed in the small boxes labeled 'C6' or 'C7' ABOVE the left/right motor mounts. Solder them in, and clip the leads off the bottom!

Steps 7 - 9:

Installing 6.8µF, 1000µF & 0.1µF capacitors

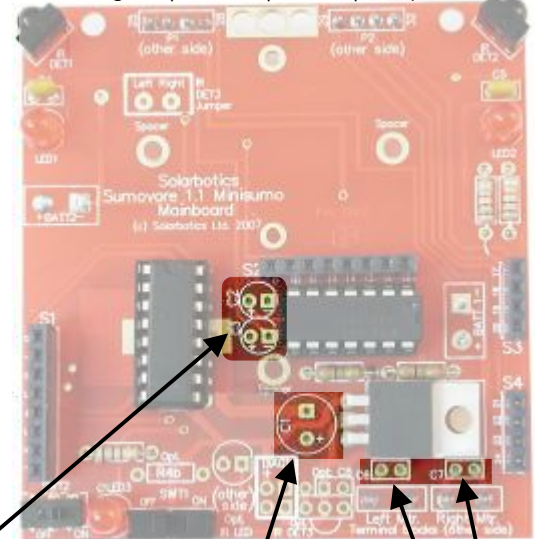

Step 7:
6.8µF (x 2)

Step 8: 1000µF

Step 9: 0.1µF (x 2)

Steps 10 & 11: SWT1 and SWT2 switch installation

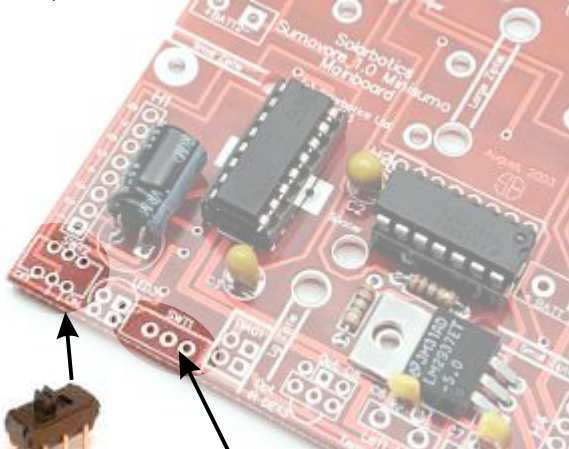

Step 11: SWT2
Enable Switch

Step 10: SWT1
Main Power Switch

Step 10 & 11: SWT1 and SWT2

No magic here - insert the switches so they're flush to the surface, and solder them in.

SWT1 is the all-important main power switch. Won't do anything without it!

SWT2 is the 'Motor Enable' switch, which will turn off the motors so you can easily tune your Sumovore without it running away on you. It'll look like one or the other shown, and both work equally well.



The Solarbotics Sumovore



Building the Mainboard Electronics - 3

Step 12, 13, 14 - LED, 8 & 4 Position Sockets:

This LED is wired in series with the infrared emitters on the front sensor daughterboard. If you see this LED on, it means the IR emitters are also on - a good sign of power and proper operation!

All LEDs have to be installed the right way around. Look carefully for the flat spot on the ring round the LED, and install it in position 'LED3' so the flat matches the flat as marked on the PCB. Another tip is to make sure the shorter leg goes into the square pad. Don't worry about the second pair of pads below the original holes - they're for future use for mounting an additional IR Emitter for rearward-looking sensors.

The two pairs of 4 and 8 position headers interface the 'brain daughterboard' with this mainboard. It's quite important that they are installed vertically - straight up & down. The 8 socket headers go in positions 'H1' and 'H2', and the 4 socket headers go in positions 'H3' and 'H4'.

The best way to do this is to insert the header strip into the PCB, and solder just one of the pins to the solder pad. Flip it back over, and bend the strip until it stands straight up from the PCB. Then go back, and solder up the rest of the pins.

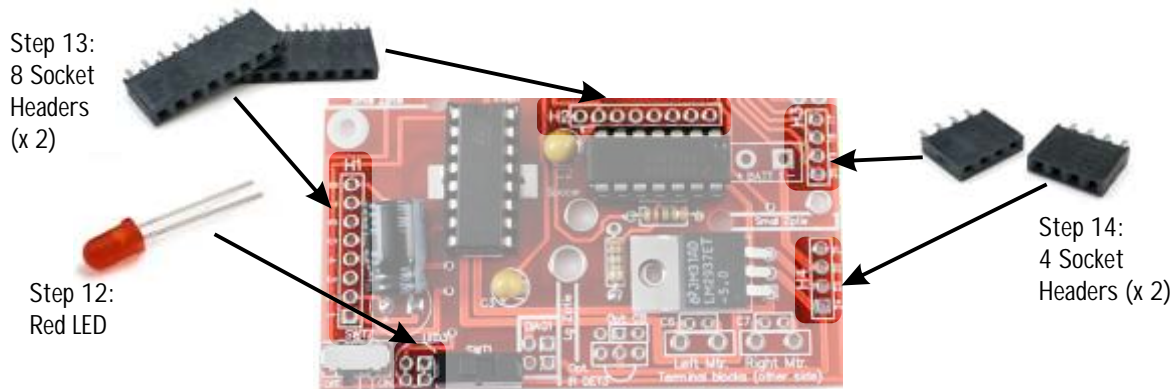

Steps 12, 13, & 14: LED, 8 & 4 Socket Headers

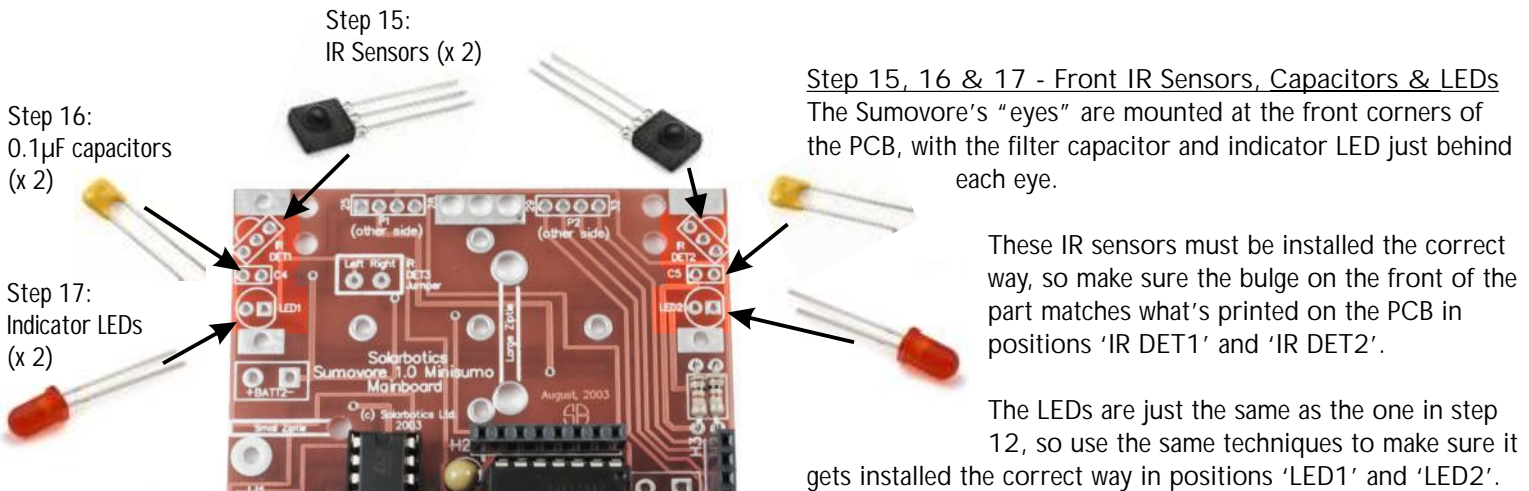

The 0.1µF filter capacitors don't mind which way they get installed, so insert and solder them in positions 'C4' and 'C5', and we'll get onto the next step!

Steps 15, 16 & 17: IR Sensors, Caps, and LEDs





The Solarbotics Sumovore



Building the Mainboard Electronics - 4

Step 18 & 19 - Front Pins and Terminal Blocks - IMPORTANT!:

Well, we're done with the top of the PCB (for now). These next two steps take place on the underside of mainboard, so even if the markings for the parts are on the top of the board, they're installed on the underside. Don't get this wrong!

Step 18: Front Pins (2 sets) are installed underneath points 'P1' & 'P2', BUT get installed on the other side!

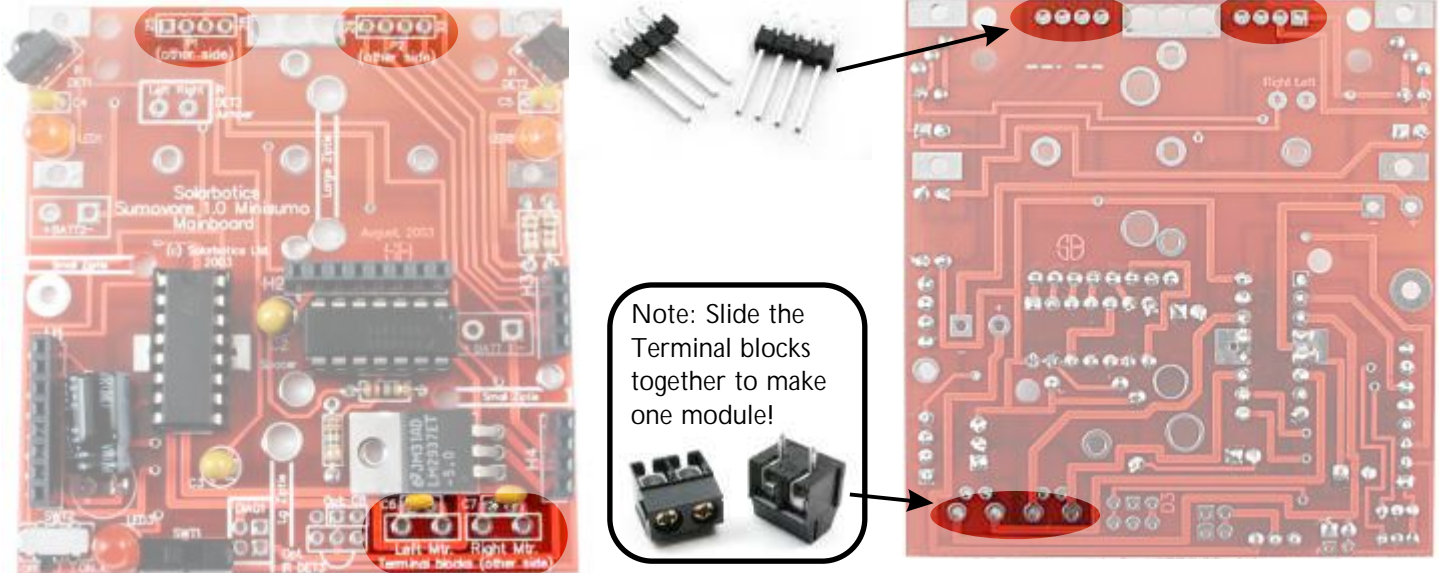

Step 19: Terminal blocks (2 sets) install here on bottom side, with side holes pointing out the back



Steps 18: Front Pins Installed



Steps 19: Terminal Blocks Installed

Mainboard PCB Finished! There - you have pretty much finished the mainboard. You will have to adjust the angle of the front pins to suit the front plate, but we'll take care of that when it's time to install the front plate.

Get up from your chair, go raid the fridge for a snack (wash your hands first, lead-boy), and enjoy having completed the first task in building your Sumovore!



The Solarbotics Sumovore

Building the Edge / IR Transmitter Electronics - 5



Step 20 & 21 - IR Edge Sensor PCB Connectors and LM555:

We're now working on a brand new board - the Edge Sensor PCB. This board holds the front edge sensors, and the infrared transmitting circuitry.

Let's start by installing the LM555 chip in the spot labeled 'IC4'.

Steps 20 & 21: LM555 and 90° edge connectors

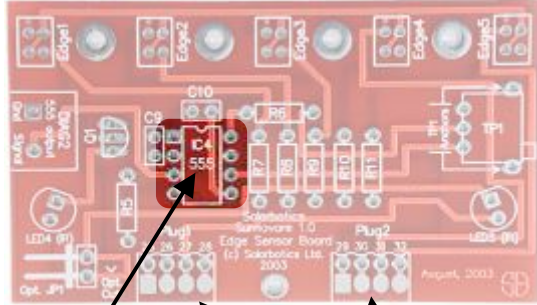

MAKE NOTE of the direction you install the chip! You want the end with the round dot in the corner of the chip to be near the notch in the symbol printed on the PCB. This is the only chip we're not putting in a chip carrier because it would make the circuit board too tall to properly fit on your Sumovore, so it's very important that you get it right the first time. Check the next assembly picture on this page to make sure it matches what you've done **BEFORE** you solder it in.

After the 555 installation, pivot the 90° connectors into positions 'Plug 1' and 'Plug 2'. These will provide mechanical and electrical connections to the rest of the Sumovore's circuitry.



Step 20:
Install the LM555
(corner dot up!)

Step 21:
90° Edge connectors
(x 2), plastic side up

Step 22, 23, 24 & 24a - 100k, 30k, 240 & 47Ohm Resistors:

If it weren't for resistors, we'd have a whole heckofalot less soldering to do! Unfortunately, that's not the case, so let's get to work. You don't have to watch the way you install resistors, but it's always nice to have all the resistors lined up with all the gold bands on one side. It's the sign of a true Sumovore craftsman...

Start with the 3k (Orange / Black / Red) resistor and install it in position 'R6'. This resistor helps set the frequency that the LM555 chip will flash our IR emitter LEDs.

Next, round up the five 240 Ohm (Red / Yellow / Brown) resistors and install them in positions 'R7', 'R8', 'R9', 'R10', and 'R11'. These resistors limit the current going to the edge-detector module emitters (yet to be installed).

Find the single 100k (Brown / Black / Yellow) resistor and solder it into position 'R5'. This resistor limits how much signal is sent to the transistor that powers the IR emitter LEDs (yet to be installed).

Last are the two 47 ohm (Yellow, Purple, Black) resistors. Install these in positions R11a and R11b. These limit the current going to the IR emitters.

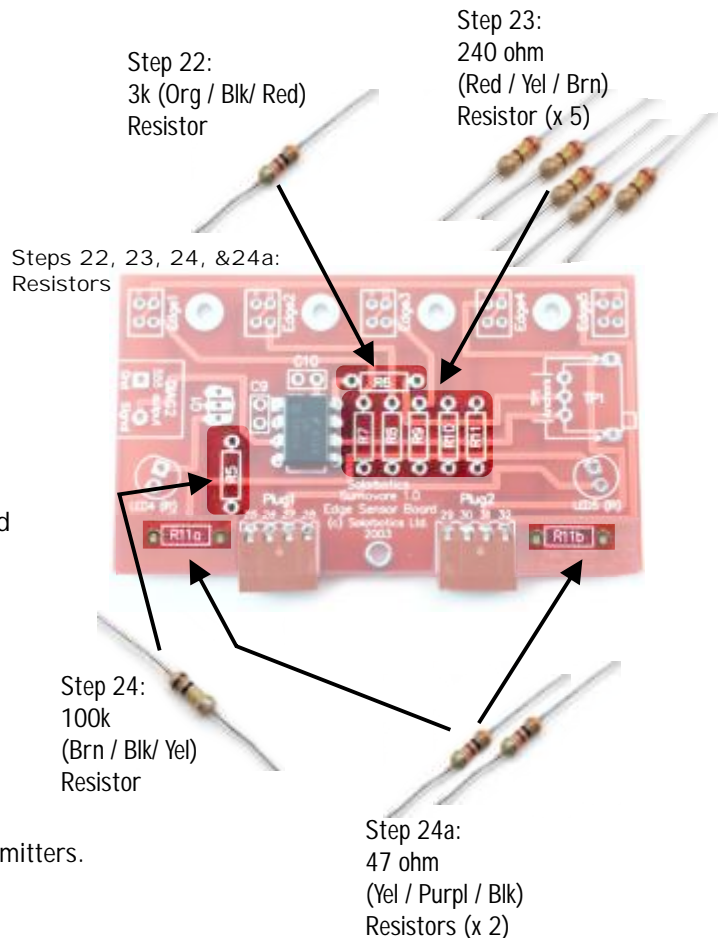

Step 22:
3k (Org / Blk / Red)
Resistor

Step 23:
240 ohm
(Red / Yel / Brn)
Resistor (x 5)

Steps 22, 23, 24, & 24a:
Resistors

Step 24:
100k
(Brn / Blk / Yel)
Resistor

Step 24a:
47 ohm
(Yel / Purpl / Blk)
Resistors (x 2)



The Solarbotics Sumovore

Building the Edge / IR Transmitter Electronics - 6



Step 25 & 26 - Installing and anchoring the 20k Trimpot:

The "trimming potentiometer" is known in the electronics biz as a "trimpot", so get used to the term. This adjustable resistor tunes the 555 timer so we can 'dial in' exactly how on-tune we want the IR emitters transmission frequency. We want this ability because there's a natural variation in the manufacture of parts, which means that no two resistors or capacitors (even if from the same batch) will measure exactly the same value. Because of this variation, we need the trimpot to let us fine-tune the circuit.

There are occasions when we will want to de-tune the circuit to make it less sensitive, like in low-light levels when the IR sensors are very responsive and see targets over 4 feet away, or the reflection off the sumo ring surface. Having the trimpot handy on the edge of the PCB for tuning your circuit will be very useful indeed!

Find your trimpot, and bend the legs down as shown in the illustration. Install it into the position marked 'TP1'.

Step 25: Bend the legs down, then install at 'TP1'

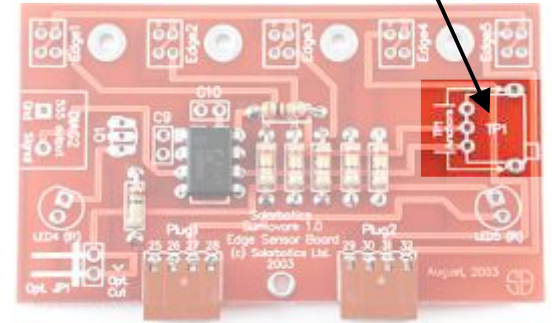
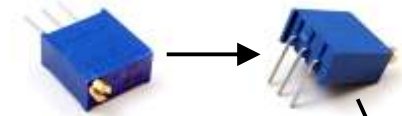

Steps 25: Preparing and Installing the 20k Trimpot

To anchor your trimpot, find a boat anchor, tie it to your trimpot, and heave'er over the side into the deep blue sea... no, no, no. What we mean by 'anchoring' is to lock the trimpot down so it doesn't wiggle around while you are tuning it. You can easily break off the trimpot if you don't. This is **IMPORTANT**, so don't skip this step even though it looks... skippable. It isn't. Do it, or we'll tell your Mommy on you.

Find one of the longer resistor clippings from your past assembly (yes, even if you have to carefully dig in the trash), and use it to straddle the trimpot. Solder it in place, so the clipping holds the trimpot snugly down in place. See? That wasn't so bad.

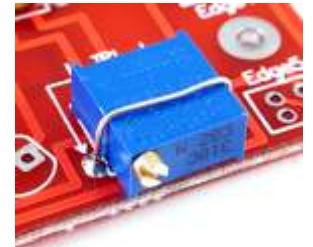

Steps 26: Trimpot Anchored

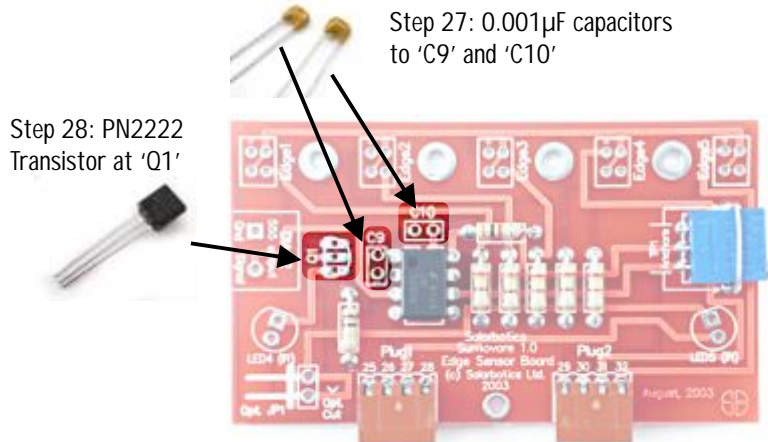

Steps 27 & 28: Capacitors and Transistor

Step 27 & 28 - Capacitors and Transistor

To function properly, the LM555 timer chip also needs a pair of capacitors. The two 0.001µF (labeled '102') capacitors (look for a '102' stamped on the side) are not polarity sensitive, so stick them in at positions 'C9' and 'C10', and solder them down.

The PN2222 is used to amplify the small signal out from the LM555 timer to the two infrared LEDs you'll be installing. The transistor is polarity sensitive, so install it so the curved shape of the transistor matches the one printed on your circuit board. Remember, clean soldering counts, so don't cause any accidental shorts on the close transistor solder pads.

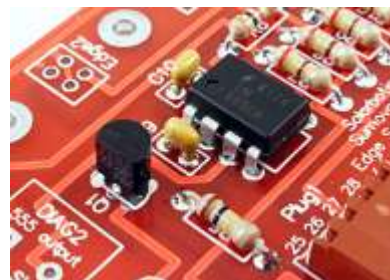

This is what it should look like after Capacitors and Transistors are installed



The Solarbotics Sumovore

Building the Edge / IR Transmitter Electronics - 7



Step 29: Install IR LEDs (x 2) to 'LED4' and 'LED5'. Short lead goes to square pad!

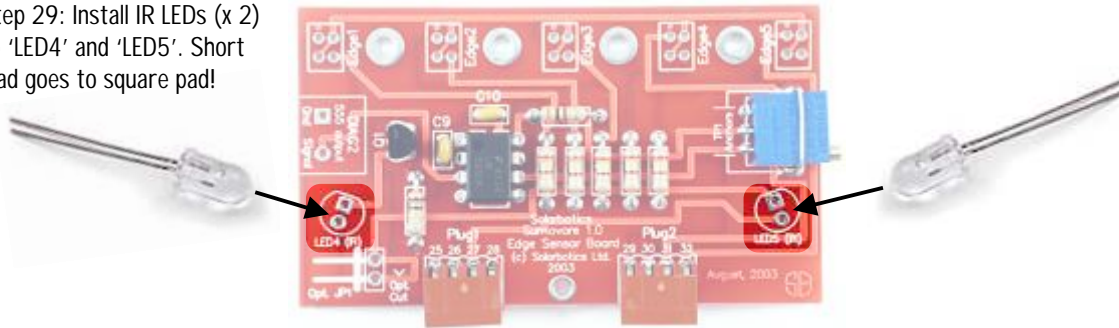

Steps 29: Infrared LED installation

Step 29 - IR LED Installation

The infrared LED is just like the other LEDs, which means it has to be installed the right-way around, or it simply won't work. SHORT lead goes into the SQUARE pad. Unlike the other LED installations, we do not want to make these sit flat against the circuit board - we want them to be spaced off just a bit so they can be bent around and aimed out the front of your Sumovore.

When installing the LEDs into the mounting pads, only insert them so far that the bump on the lead disappears. You want about 1/8" (3mm) space. Solder the LEDs into place, then bend them gently over to the outside edge of the circuit board.



IR LED Installation

Step 30 - Edge Sensor Preparation

The QRD1114 edge sensor is a combination unit, containing both an IR emitting LED and an IR-sensitive phototransistor. The active elements of both halves point downward, so that any object below will reflect the IR light back to the sensor for detection. As long as you're not in the immediate vicinity of a light-absorbing black-hole, these sensors do a good job of reading reflections within a short distance. Unfortunately, these sensors don't quite fit our application - they point the wrong way!

This is another of those important things that you simply cannot be messing up, so WAKE UP! READ THIS! It's IMPORTANT!

We're going to have to fold the sensor leads over in a careful way to make them fit onto the circuit board, so let's start by identifying which way is up. You'll notice on the front face of the sensor that there is a dimple near one corner - that's LEAD 1 (and the collector of the phototransistor). Fold this lead and the one closest to it 90° up so they are flat to the sensor body.

Get one of the circuit board, and use it as a spacer for folding over the other two leads - this will set the proper spacing distance for all the leads so they will fit well into the edge sensor PCB. Is this as clear as mud? Refer to the pictures below, and all will make sense.

You'll be doing this for all the edge sensors in your kit, which may be two, four, or five, depending on the complexity of kit you received.

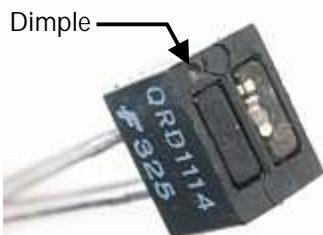

Step 30: Identify the side with the dimple...



...then fold the leads on the dimple side down flat to the sensor...



...and use the circuit board as a spacer to fold over the other two lead over the first pair.



The Solarbotics Sumovore

Building the Edge / IR Transmitter Electronics - 8

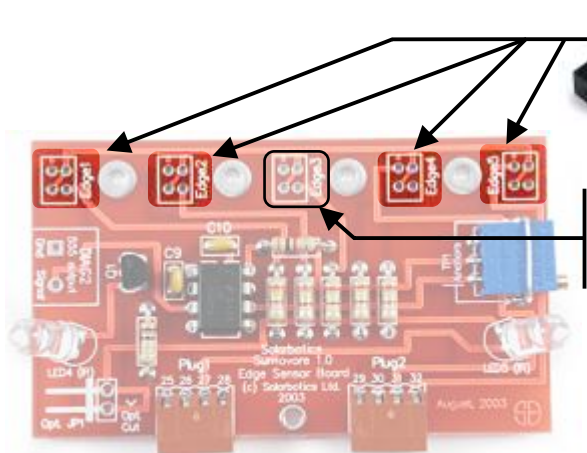

Step 31: Install Edge Sensors (x 4) to 'Edge1', 'Edge2', 'Edge4', and 'Edge5', (yup, not 'Edge3')

A sensor gets installed in position 'Edge3' only if you have a microprocessor brainboard add-on (the extra sensor is included in the add-on kit).

Steps 31: Edge Sensor Installation



Installation complete. Note that all sensors sit so the IR transmitter (clear) is always on the left side.

Step 31 -Mounting the Edge Sensors: This board is designed so you can use as few as two sensors, or as many as five. We supply you with four, so you are sure to detect white lines on the left & right.

When using the standard discrete brainboard, the sensors at 'Edge1' and 'Edge2' are wired in parallel, as are the ones at 'Edge4' and 'Edge5'. This gives you a backup sensor in case if one sensor is damaged in the heat of battle. It also makes the line-follower behavior more stable.

When using a microprocessor brainboard, all the sensors are independently available to the microprocessor, and there is the option to install a fifth sensor at position 'Edge3' which is useful when programming an advanced line-follower robot.

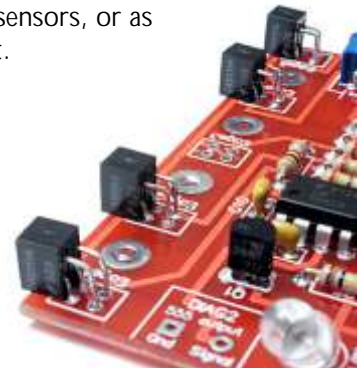

Note the clean sensor installation. No touching wires, no solder blobs, and no chocolate stains.

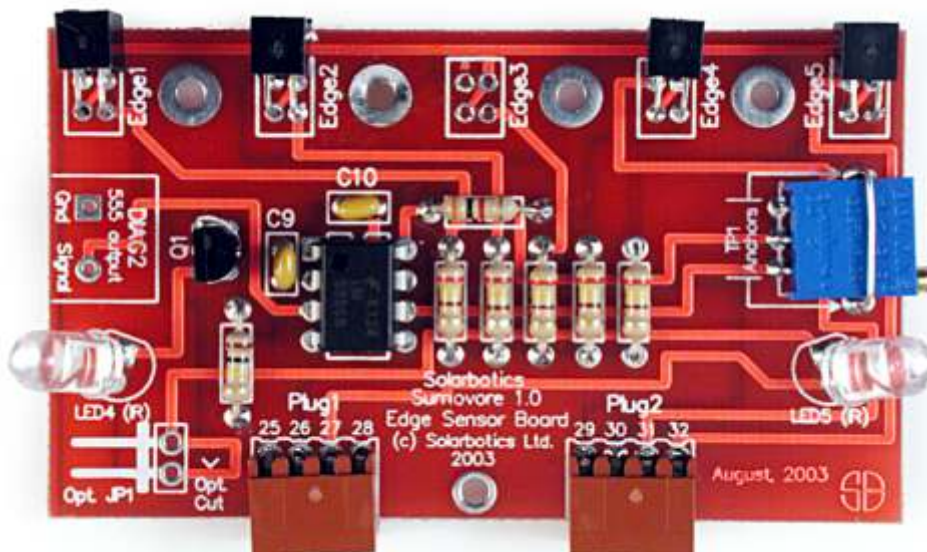

Finished! There - that's what your complete Edge Sensor Board should look like when you're finished. One step closer to Sumovoraciousness...



The Solarbotics Sumovore



Building the Mainboard Electronics - 9

The Discrete Brainboard: BEAM robots usually have simple, robust controller systems, and the Sumovore follows this tradition. Although we're using a 74HCT240 octal inverting buffer chip in the circuitry, there aren't any truly radical BEAM-style or analog concepts behind it, so we refer to this brainboard being "discrete," as in "composed of many separate pieces."

Building a sumo robot brain can be done as simple as using three DPDT relays (see the book "Junkbots, Bugbots, and Bots on Wheels"), but in doing so, there won't be a very wide scope of behaviors in the sumo robot. On the other hand, we've built over 20 Sumovore prototypes, each time refining what we can do with a simple controller circuit, and indeed, there's some subtle elegance to the discrete brainboard, like:

- Deceleration before reversing the gearmotors to keep the sumo plate edge from lifting off the surface
- Opponent sensor false-trigger filtering
- Smooth left / right opponent tracking
- "Sumo-dance" inhibiting (so the Sumovore knows to try something different after 5 seconds of locking up with the opponent)
- "Edge-charge" inhibiting (so the Sumovore doesn't repeatedly head-on charge the sumo ring edge)
- Selectable "Line-follower" or "Sumo" mode (so you can use the Sumovore for line-following contests)
- Optional rear-looking sensors (active looking, or passive sensing of opponent's IR transmissions)

We designed this brainboard to be very robust and straightforward to build and use, so even if you are planning to use a microprocessors with your Sumovore, you can use the discrete brainboard as a benchmark to compare your microprocessor brains against. Not sure if there's a bug in your code or if it's a hardware problem? Trade out the microprocessor brainboard for the discrete brainboard and see if the problem goes away. Last minute competition changes mess up your code? You can always fall back on the discrete brainboard. For these reasons, we encourage you to build this brainboard even if you have every intention of eventually plopping a microprocessor on your Sumovore.

Note: If you're using Hydro-X or similar solder with water-soluble flux, be sure to wash the board off at the end of construction! Failure to do so will cause erratic behavior in your Sumovore!

Steps 32 & 33: Carrier and 74HCT240

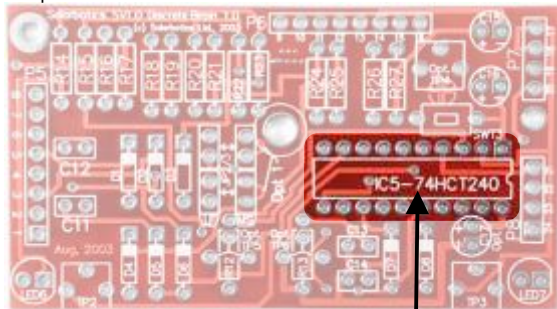

Step 32: Install Chip Carrier at 'IC5'...



Step 33: ...then install 74HCT240 into chip carrier. Or if you're feeling unlucky, wait until all soldering is done

Step 32 & 33 - The Chip Carrier and 74HCT240: We're going to install a 20-pin chip carrier first, simply because it's an ugly mess to desolder a backwards 74HCT240. Really, you don't want to do it.

Just like when you installed the chip carrier for the mainboard's two chips, you want to mate the position of the carrier's notch with the notch printed on the circuit board at position 'IC5-74HCT240'. Yes, we know it doesn't say 'IC5-Chip Carrier'. Don't be a smarty-pants!

After you've finished inserting the carrier, find your 74HCT240, and insert it into the carrier, matching up the notch in the chip with the notch on the carrier (this notch-alignment-thing is pretty cool, eh?).

Note: (referring back to step 4/5...) A major reason for using a chip carrier is so that you can isolate the chip during assembly, then press it in right at the end of the job. If you've had some bad luck lately and don't want to risk it, just install the carrier NOW, and install the chip near the end of constructions



Complete carrier & chip installation. Note the notch position!



The Solarbotics Sumovore

Building the Discrete Brain Electronics - 10



Step 34 - Optional Line Follower / Mini-Sumo Selector:

If you don't know, don't care, or know but don't care what line-follower is, or simply want to get the soldering over with, you can totally skip this step. Line-follower is a neat event, as brute force isn't as important as your skill in tuning the sensors. All we're going to do is add some pins and jumpers so you can activate line-follower mode. If you don't have any lines in your house, then it's obvious you should skip this step.

Start by using a sharp knife or razor to cut a small chunk of the chocolate bar you've got hidden in your desk, and eat it. Feel more energized? Good. Now take that same knife (after cleaning off the chocolate...) and use it to scrape through the red masking and the underlying copper tracks at the two points marked by 'Opt 1'. By default, the discrete brainboard is hard-wired for mini-sumo mode, so by doing this, you're preparing the circuit connections to be re-routed for line-follower mode.

Solder the four jumper pairs to the positions at 'JP2/3'. It's a bit tricky, as the pins will fall out when you turn the circuit board upside-down. The solution? Have a friend hold them in place from the bottom with some needle-nose pliers while you solder them in, or use a small ball of clay to keep it stuck in until it's soldered. If you're good with a soldering iron, use a left-over chunk of IC-holding foam stuck on the long-pin side to keep them from falling out. 2-second soldering won't melt it.

After the pins are soldered in, install the two jumpers across the two jumper pin pairs on the RIGHT side, in the set labled "MS" (MS - for "Mini Sumo"). If you want line-follower mode, reposition the two jumpers to the LEFT, where it says "LF" (Line follower mode is covered in the "Troubleshooting" section).

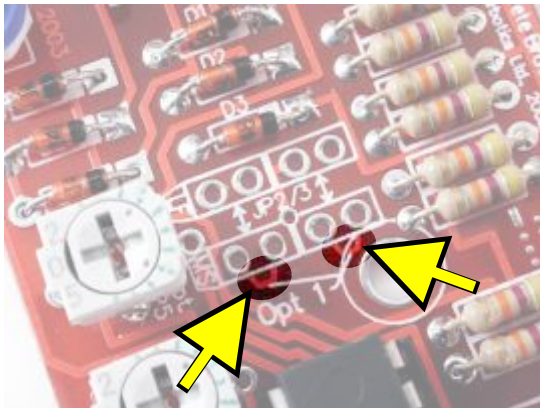

Step A:
Identify
the traces
to cut

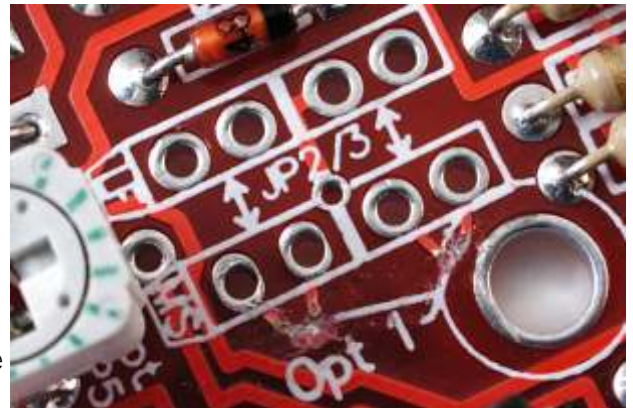

Step B:
Sever those
two traces!

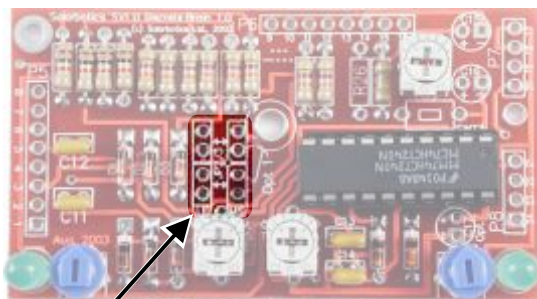

Step C: Install the jumper pairs (x 4)
in positions 'JP2/3'

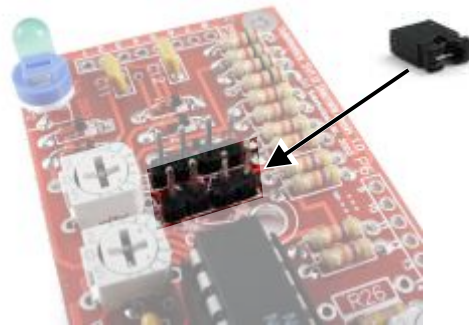

Step D: Install the jumpers on the
pin pair on the 'MS' side (right side)



Finished! Ready for mini-sumo
or line-follower competitions!



The Solarbotics Sumovore



Building the Discrete Brain Electronics - 11

The reverse-and-turn feature is controlled by the two 2-meg trimpots. Each trimpot sets how long the Sumovore spends in reverse-and-turn mode when that particular corner is triggered by a white line.

Step 35 - 2M Trimpots for Reverse-and-Turn: The trimpots make it easier to adjust your Sumovore for best performance. Solder each 2 Megaohm trimpot to the three pads that are joined by lines and labeled 'Opt TP5' and 'Opt TP6'. Don't worry about where to set them at the moment, as we'll cover that later in the tuning section.



Finished Installation

Step 35: Install the 2M trimpots at positions 'TP5' and 'TP6'

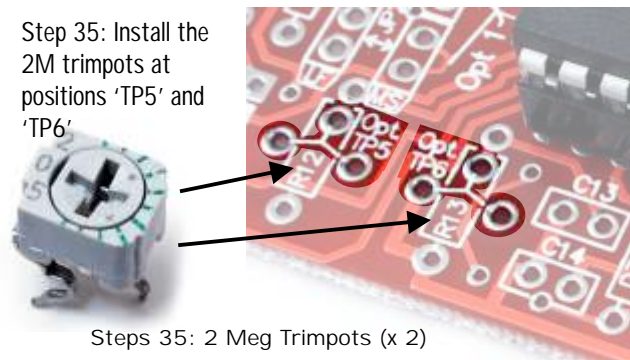

Steps 35: 2 Meg Trimpots (x 2)

Step 36, 37, & 38: 1k, 47k & 470k Resistors: A good number of the components on the discrete brainboard are resistors, so let's get to work.

Start with the four 1k (Brown / Black / Red) resistors and solder them into positions 'R14', 'R15', 'R16', and 'R17'. Two of these resistors limit the power going to the indicator LEDs, and the other two limit the current in the IR sensor over-ride portion of the circuit (when it sensors detect the edge and need to steer it away from the edge).

The 47k (Yellow / Purple / Orange) resistors sit in positions 'R18', 'R19', 'R20', 'R21', 'R22', 'R23', 'R24', and 'R25' (yes we know we could have just said R18-25, but then we couldn't say we wrote a detailed construction manual, could we?). These resistors are used for many purposes, including IR sensor biasing, edge-ram behavior suppression, sumo-dance behavior suppression, and fostering world peace. If you want full details, please check the schematics at the end of the manual.

Step 37: Install 47k resistors (x 8) at positions 'R18' to 'R25'

Step 38: Install 470k resistor at position 'R26'

Step 36: Install 1k resistors (x 4) at positions 'R14' to 'R17'

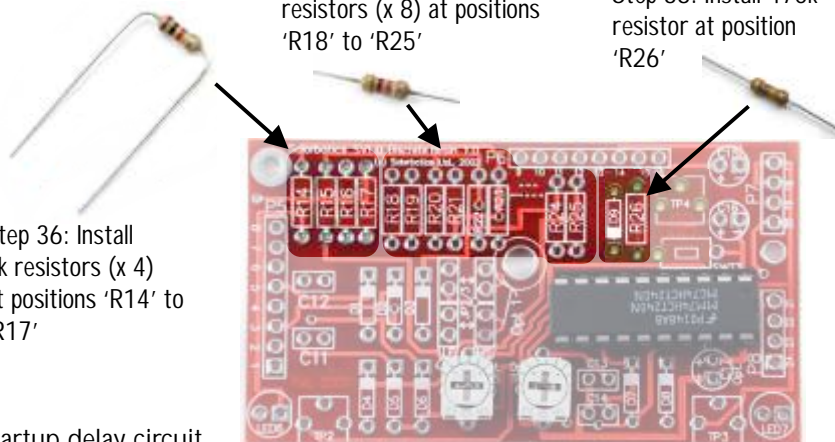

Steps 36, 37 & 38: 1k, 47k, & 470k resistors

The single 470k (Yellow / Purple / Yellow) resistor in position 'R26' is part of the 5 second startup delay circuit.

This step sets up the resistor values used to configure the startup timer for your Sumovore. Once configured, you shouldn't need to make any further adjustments. This brainboard uses a pair of inverters, capacitors, and resistors arranged in series to create a delay of (ideally) 5 seconds. One of these inverter / capacitor / resistor stages is designed to let you tweak the startup timer so you can tune your 5 second startup delay.

Step 39 - 2M Trimpot for Startup Delay: Solder the last 2M trimpot into position 'TP5'. Turning it to the right (clockwise) adds time to the delay; to the left (counter-clockwise) removes time.

Step 39: Install 2M trimpot at 'TP4'

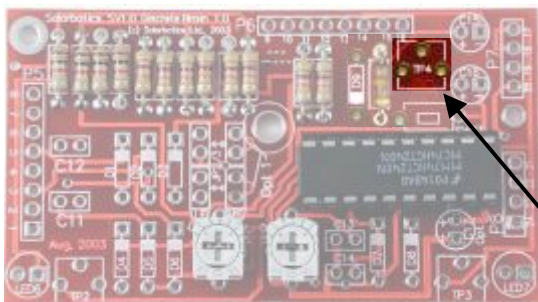

Step 39: Installing 2M trimpot



Finished Installation at 'Opt TP4'



The Solarbotics Sumovore



Building the Discrete Brain Electronics - 12

Step 40 - Diodes: There are nine diodes (yup, not 8, not 10; 9) in your Sumovore's discrete brain. Diodes are polarity sensitive, and they have a black band to show which way is the cathode (negative end). Install the diodes with the black band in the same position as the band printed on the circuit board in positions 'D1', 'D2', 'D3', 'D4', 'D5', 'D6', 'D7', 'D8' and 'D9' (whew!).

Step 41 - 0.47µF Capacitors: The four 0.47µF (labeled '474') capacitors get installed in positions 'C11', 'C12', 'C13', and 'C14'. The capacitors aren't polarity sensitive, so don't worry about the way they get installed.

Step 40: Install diodes at positions 'D1' to 'D9' (note orientation!)

Steps 39 & 40: Diodes and Capacitors

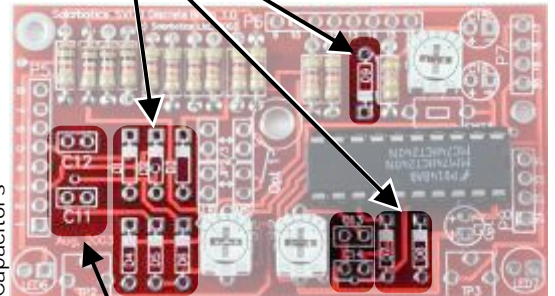

Step 41: Install 0.47µF capacitors at 'C11' to 'C14'

Steps 42 & 43: 10k Trimpots and LEDs

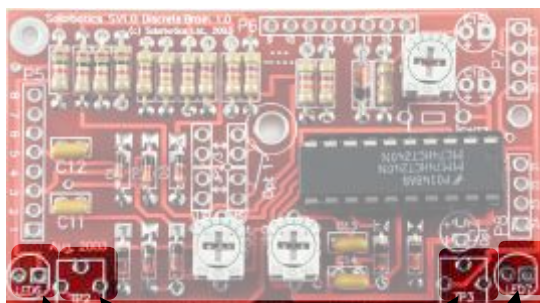

Step 42: Install 10k single-turn trimpot at 'TP2' and 'TP3'

Step 43: Install LED at position 'LED6' and 'LED7' (watch polarity!)

Step 42 & 43: 10k Trimpots & LEDs: The 10k single-turn trimpots are how you'll be setting the sensitivity of the edge detectors. Turning them to the right (clockwise) makes them more sensitive; the other way (counter-clockwise) makes time go backwards (just a counter-clockwise joke there...).

Install the 10k (labeled '103' on the side) trimpots in positions 'TP2' and 'TP3'.

The LEDs show when the edge sensors have detected the edge. Everybody likes blinky lights - it's what makes robots (and Star Trek command consoles) cool. Remember, LEDs need to go in the right way, so make sure the flat spot on the LED's shoulder matches the flat spot on printed on the circuit board at positions 'LED6' and 'LED7'.

Step 44: Two 6.8µF tantalum capacitors at positions 'C15' and 'C16'

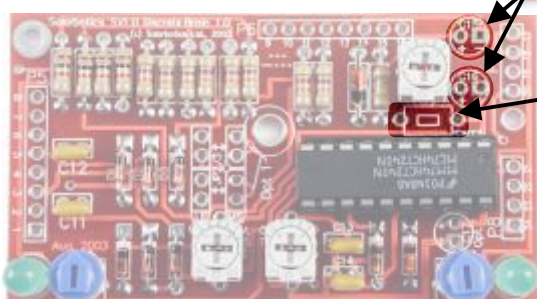

Step 45: Reset Switch into 'SWT1'

Step 44 & 45: 6.8µF Capacitors and Reset Switch: The two 6.8µF capacitors are installed to 'C15' and 'C16', and are part of the startup circuitry. These capacitors are polarity sensitive, so be sure the shorter leg goes into the square pad (square pads usually indicate '-', which is what the cap's short leg is). The cap also shows a little "+" sign near one leg (the longer leg), just so you have two ways to identify the legs.

The switch is a bit tight to install at position 'SWT3' (sorry, we should have done that earlier in the assembly process), and resets the startup timer when released. It's also a bit hard to reach, but that was planned that way so it doesn't accidentally get hit by the opponent in the heat of combat.



The Solarbotics Sumovore

Building the Discrete Brain Electronics - 13



Step 46 & 47 - Eight and Four Pin Header Rails: Here's another one of those tricky installs, where we want you to install the parts on the underside of the circuit board. We're going to install the pins that will connect the Discrete Brainboard to the Mainboard. Since we're sure you don't want to install the brains in upside-down, just remember that they all are soldered in from the bottom. Don't worry, we'll be reminding you to do this several times yet.

Take the two 8-pin headers and install them in positions 'P5' and 'P6', with the short end being soldered to the board. It's quite important to make sure that the pins are installed straight up-and-down, 90° degrees to the circuit board. The best way to do this is by soldering only one pin on the header, then eyeball how it's sitting. It's easy to remelt the solder and tweak the alignment if only one pin is soldered. When you're happy with the alignment, go crazy and solder in the remaining 7 pins.

Use the same procedure on the 4-pin headers, and install them in positions 'P7' and 'P8'. Same drill - solder only one pin and make sure that the header is installed straight up-and-down.

A Tip for the Brave: Want an ideal way to mount your pins? Instead of the above steps, mount the pins into the sockets on the main board. Drop the Discrete brainboard onto the pins, and solder a pin on each end of the pin strip. Pull the brainboard out (with all 4 strips), and finish soldering. Now you're guaranteed that each pin will mate with each socket!

Warning: You may melt the sockets if you take too long tack-soldering in the pins! That's why you have to be brave doing it this way! BUT, it's also the best way to make sure everything aligns up nicely!



Step 46: Install 8-pin header underneath at 'P5' and 'P6'. Make sure it's straight up-and-down!



Steps 46 & 47: 8 and 4 pin installation UNDERNEATH!



Step 47: Install 4-pin header underneath at 'P7' and 'P8'. Make sure it's straight up-and-down!

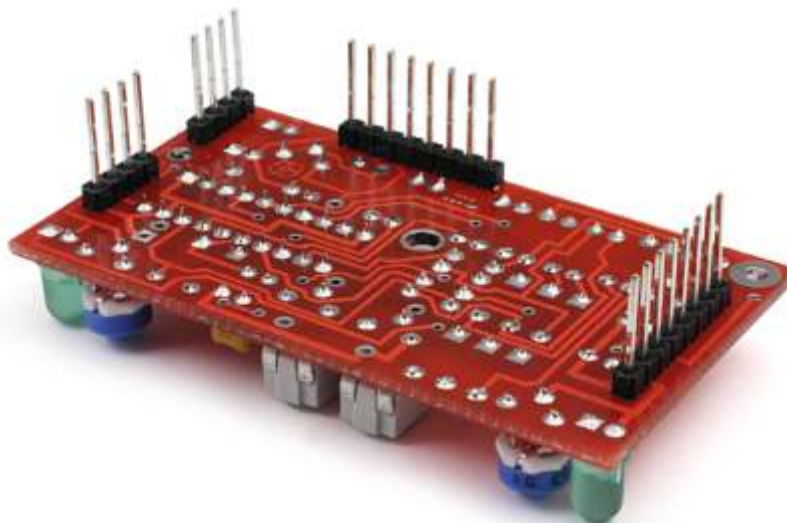

Final Installation. See? Pins Mounted UNDERNEATH!



The Solarbotics Sumovore



Building the Body - 1

Enough of the continuous soldering - let's get to work actually giving our Sumovore a body! Start with the electronics mainboard, as it's the ...main board... for the whole robot.

Collect the metal baseplate, and associated screws & spacers. Not sure which is which? Have a ruler handy to measure their lengths.

Step 1 - Mount the Baseplate to the PCB: Use two of the #2 x 3/8" self-threading screws (these are the ones that don't have a sharp point), and screw them into the PCB at the two front positions (as shown). They'll lightly thread themselves into the PCB so they stay put.

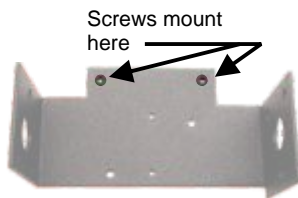

Step 1: Insert #2 x 3/8" self-threading screws to front 2 positions

(screw shown actual size - note blunt tip)

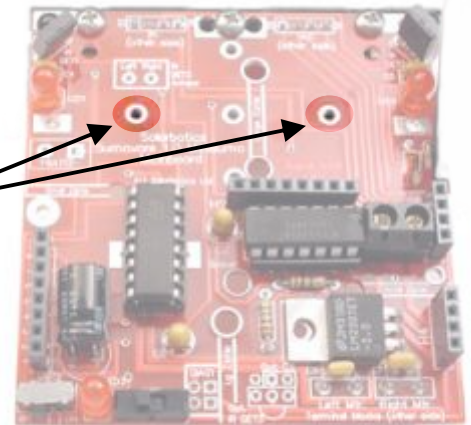

Step 2: Mount baseplate to PCB with 2 screws and 2 nylon washers

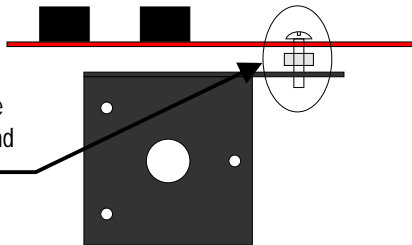

Step 2 - Nylon Spacer: Put a 1/8" nylon spacer on each screw, and thread the whole works to the baseplate. Don't forget these spacers! These spacers keep the electronics from potentially shorting out against the metal baseplate (usually, a bad thing!).

You'll need a firm grip on your screwdriver to fully drive the self-threading screws into the metal baseplate - don't be afraid to use some pressure!

Step 3 - Rear Screw Installation: With the front two screws in tight, you should be able to slide the nylon spacer between the PCB and baseplate so it's held there by friction. This will make installing the final screw and washer pretty easy.

Step 3:
3/8" self-threading screw.
Don't forget the nylon spacer!

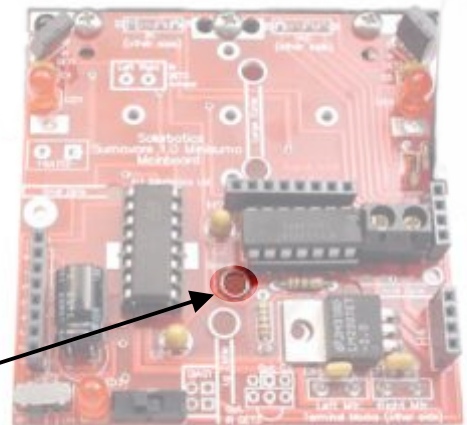

Baseplate mounting to PCB complete!



The Solarbotics Sumovore



Building the Body - 2

Step 4 Preparing the Motors with 0.1µF Noise Suppression Capacitors:

Some of the electronics on the Sumovore can be sensitive to the electrical noise that the motors make, so we're going to nip that in the bud now with a pair of 0.1µF capacitors per motor.

Use some sandpaper or a file (or if desperate, the scratchy teeth of pliers) to shine up part of the motor body in two spots, each near each of the motor terminals.

Solder each capacitor from one terminal to one of the shiny spots on the motor body. This job is simplified if you pre-tin the motor's shiny spot with a dab of solder.



Step 4a: Use a file to scrape and make a shiny spot on the motor near the motor connection tab



Step 4c: Mount a capacitor to each side of the motor, with one leg soldered to the tab, the other to the body



Step 4b: Pre-tin the shiny spot with a bit of solder - it may take a while if you have a cooler soldering iron!

Step 5 Mounting the Motors:

The baseplate makes mounting the motors a snap.

The holes auto-align to the holes in the motor and the nub just behind the output shaft.

Pick a motor, align it up, and use two #4-20 x 1/2" long thread-forming screws to secure it to the plate!



Step 5: Mount motors, each with two #4-20 x 1/2" long screws (shown actual size)

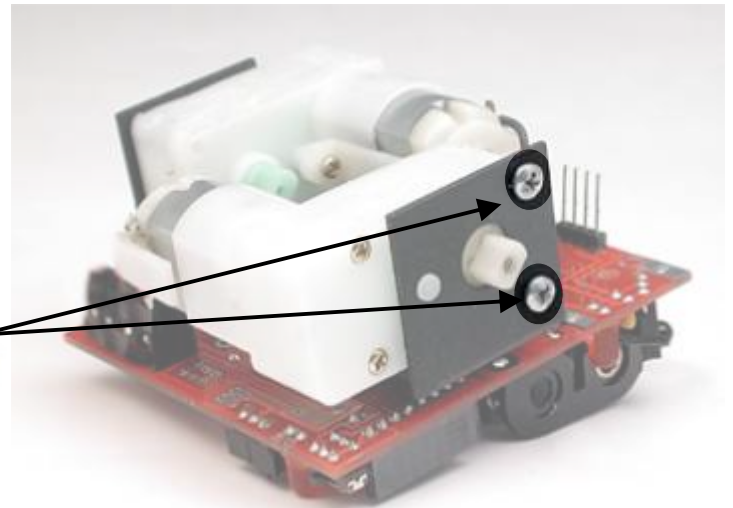

Step 5a Trimming Rear Motor (Optional):

You may want to consider trimming off one of the motor retaining strap mounts. "And why would we want to do that?" you may ask.

Firstly, it makes your Sumovore a bit smaller, which is good considering that the Sumovore is very close to the maximum size limit.

Secondly, if (and when) the Sumovore gets tipped backwards in the heat of competition, the strap mount lifts the robot off the wheels, practically guaranteeing that it won't recover from being tipped back. Shave the mount off, and the Sumovore keeps traction for over 90° of tipping, which lets it keep on fighting longer!

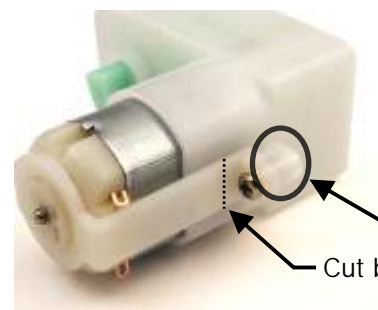

Step 5a (Optional): Cut the motor retainer and snip off the retainer mount

Optional rear motor streamlining

You don't need to do this step now, as you can do it after you've finished your Sumovore, but it is more convenient to do it at this time.



The Solarbotics Sumovore



Building the Body - 3

Step 6 & 7 - Installing the 2AA Battery Holder: Snip off most of the battery holder's wires so there's only 3cm (1-1/4") left. Solder the wires to the battery power terminals on the top of the mainboard, red to round pad, black to square.

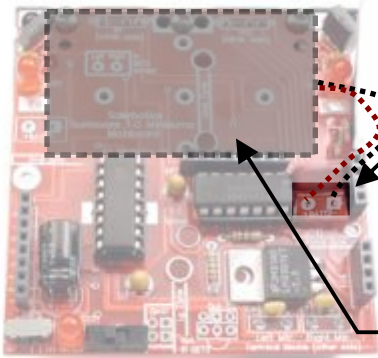

Step 6 & 7 - 2AA Battery Holder Installation and Wiring

Step 6:
Clip 1-1/4" off
2AA holder wires;
Solder to mainboard

Screw this bad-boy down with the two included #2x1/4" pointy screws. If the holes feel loose, melt a bit of solder into the holes, reducing the hole size until the screws can get a good "bite".

Step 7:
Tuck 2AA pack
between sensors
and screw down



2AA Battery Pack Installed and Wired



Step 8: Solder battery-pack wire cut-offs to front motor (black to motor tab nearest mainboard), then connect to terminal block

Step 9: Solder short wire clippings to the rear motor and connect to terminal block

Step 8 & 9- Wiring up the Front and Rear Motors: Start with the front motor (nearest the 8 pins) and solder the remaining wire you clipped from the battery pack to the terminals on the motor. If you solder the red wire to the motor tab nearest the mainboard and the black wire on the other tab, you'll be matching what we're doing and won't have motor rotation problems later.

Run these wires over to the terminal blocks, and strip / insert the black wire into the terminal block hole nearest the corner, and screw the retainer screw down. Strip and insert the red wire into the next hole, and tighten it down.

The terminal block is sitting right next to the rear motor, so we only need a bit of wire to connect it up.

Clip 1" (25mm) of the red and black wire off the 4 AA battery holder, and use these pieces to connect the rear motor to the terminal block, again by soldering the red wire to the motor tab closest to the mainboard and the black wire to the other motor tab. Insert and tighten the black wire into the next available terminal block hole, with the red wire in the last position.

There - you're sooo close to finishing your Sumovore, you're probably going to ignore any bodily demands to eat or sleep until you're finished!



Get some wire for the other motor from the other battery pack

Rear motor gets right terminal block (black, red)

Front motor gets left terminal block (black, red)

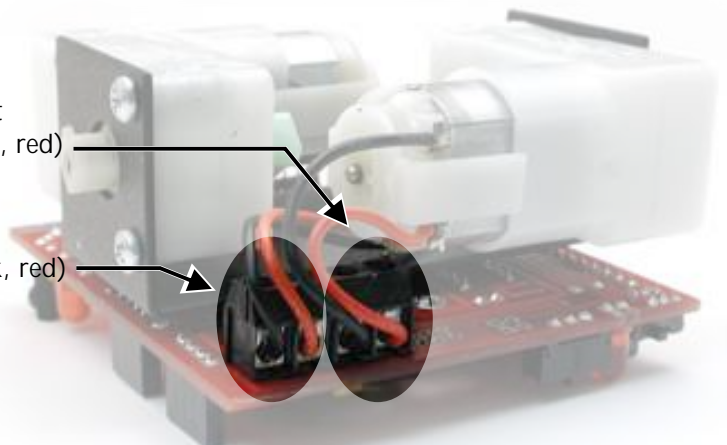

Motor wiring to terminal block finished



The Solarbotics Sumovore



Building the Body - 4

Step 10 - Front Plate Installation: Now we're getting to the point where the Sumovore is beginning to look like a real robot! We're going to install the front plate, but before we do, we want the pins that connect to the front edge sensor board to match the same angle as the front plate. Do this by first manually placing the plate up against the mainboard (as if it were already screwed on), and then examining the angle of the pins. To start with, they'll be straight up-and-down. Put down the front plate and pick up your favourite pin-bending tool (we like needle-nose pliers for this job) to grab each set of four and gently bend the set towards the plate. When the pin angle matches the angle of the front plate, you're ready to screw the front plate on.

Install the front plate with the larger three thread-forming screws, from the topside of the mainboard into the holes of the steel tabs. Thread-forming screws are a bit difficult to screw into the holes in the steel, so make sure you have a phillips screwdriver with a comfortable grip.

When done, install the front edge sensor board and see how it fits. It should slide in right next to the front plate, with little problem.



Checking pin alignment with the plate angle...
Nope, not the same!

Step 10: Align pins to angle of front plate, then screw on with 3 thread-forming screws

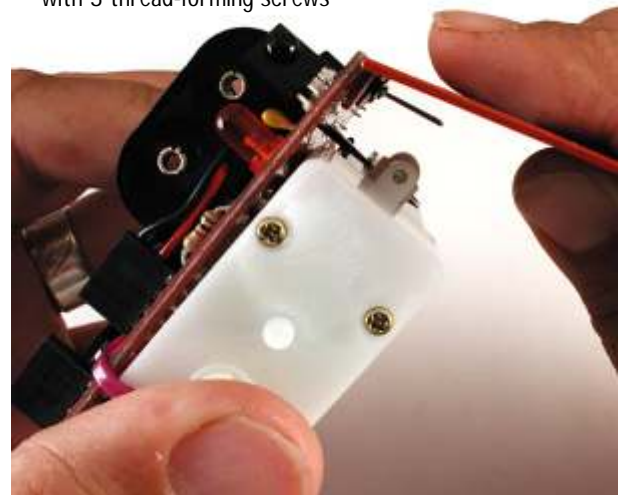

A few bends later, and the pin angle matches the plate



Screwing the plate on with 3 thread-forming screws

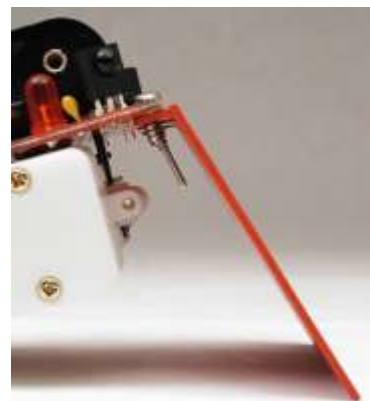

Front plate screwed on, with edge sensor circuit board pins aligned



Test installation of front edge sensor board



The Solarbotics Sumovore



Building the Body - 5

Step 11 - Bottom Battery Pack Installation: Let's attach the quad AA battery pack holder to the Sumovore.

We prefer to attach the pack, then solder it to the battery connection points below in front of the motor, but some people prefer to solder the wires, then attach the pack. Your decision (no real advantage either way). Just make sure that you're soldering to the right battery connections, as there's one for the 2AA holder, and one for the 4AA holder, and they can't be reversed! Bad Sumovore builder, BAD! Make sure your battery connections are going to the ones shown in the pictures, and all will be fine.

The baseplate has two holes for accepting the long #2 x 1-1/4" thread-forming screw that pass through the two custom holes in the battery pack. The standard holes in the battery pack simply don't work, so we've custom drilled two new holes to match the holes in the baseplate.

Before screwing the battery pack in, use a sharp knife and cut some of the rib away from around the hole. This rib will interfere with the head of the screw, so trim it back about 3mm (1/8") from each side of the hole, flush down to the bottom of the pack.

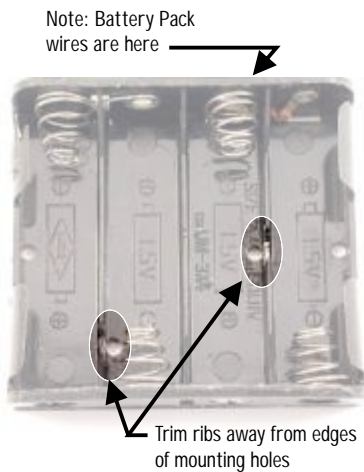

Drop the screws in, align up the holes, and secure the battery pack to the baseplate. It will take a bit of force to make the screws go in the first time (remember, you're forming threads in the baseplate's metal), but don't overdo it. you only have to make the pack gently snug up to the motors.

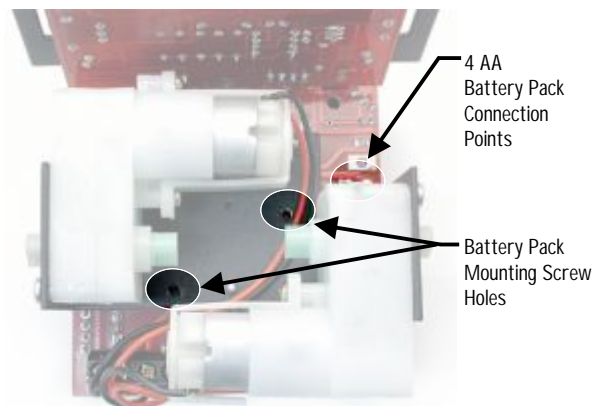

Step 11: Locate baseplate holes for 4AA battery pack holder screws

Step 12 - Bottom Battery Pack Soldering: Now that your battery holder is firmly in place, cut down the wires to a suitable length and solder them to the underside of the mainboard on the right side (viewed from bottom).

You can see the solder points just ahead of the right motor (viewed from bottom), with a square pad labeled '-' and a round pad labeled '+'. These pads are clearly labeled '+Batt-' on the topside, but it's mostly obscured by the top battery pack. Black wire goes to '-', the red to '+' (but you knew that already, RIGHT?!? Of course. Sumovore builders are smart people).

Step 12: Trim down and solder the battery holder wires to the '+' and '-' solder pads on underside.





The Solarbotics Sumovore



Building the Body - 6

Step 13, 14 & 15 - Brainboard Installation, Battery Installation and Initial Power-up: Yup, you read right - time to fetch the brainboard, then batteries, and get ready to go. Gather up your batteries, but before you go willy-nilly (except anybody named "Willy" - only you may go willy-nilly) and install the batteries and brainboard, you must check a few things.

- 1 - Wires from the top battery holder are properly soldered (black to square pad, red to round)
- 2 - Wires from the bottom battery holder are properly soldered (black to square pad, red to round)
- 3 - Batteries are NOT wired in parallel (I.e.: Sharing same solder connections to mainboard)
- 4 - Motor enable switch is in the left position
- 5 - Power switch is in the left position

Install the brainboard on the rear of your Sumovore. Careful to align up all the pins then push the board into place. With 24 pins connecting the two boards, it may take fair bit of push to get the brainboard installed. Don't bend any pins over! Press it down until the board seats - you'll see 1/4" of bare pin left. This is normal - exposed pins have no effect on the performance of the robot.

All good? Good. Install 5 of the 6 batteries. Then as you install the last battery, pay special attention to your nose, fingers, and ears. If you SMELL anything strange, FEEL heat, or HEAR any sizzling, POP THAT BATTERY OUT! Those are nasty signs that something went wrong, most likely something like a solder blob shorting out power connections, or you soldered BOTH battery holders to the same point. If you pop the battery in and nothing happens... well, that's a good thing at this moment.

Next, slide the power switch to the right (that's the bigger switch of the two).

Hopefully, the red LED right next to the switch will illuminate. This LED is wired in series with the IR transmitting LEDs at the front of the robot, so if this red LED doesn't light up, there's an IR transmitting problem. Ummm... you do have your edge sensor board still installed, don't you?

If the red LED is on, then pick up your Sumovore and touch an edge sensor. Remember, the sensors are looking for a reflection, so if you're testing your Sumovore on a white table surface, it'll think its continually reading a white edge and activating the "reverse-and-turn" behavior. Does the green LED on the corner of the discrete brainboard light up when you get close to the edge sensor? Try turning the 10k single-turn trimpot for that side clockwise (adds sensitivity). It should turn on, and stay on for a second or two after you remove your finger. Try it with the other side. It works too? Excellent...excellent!

Now, slide the motor enable switch to the right (the 'on' position). The motors will both activate, unless if you've turned the power off then on, at which point the startup delay circuit is doing it's job (delay could be from 3 to 10 seconds before motor activation). Activating an edge sensor will stop one motor and reverse the other for a short duration, then both go forward again. Check both sides for similar behavior. Things look good? Excellent!

Last test - the opponent detection sensors. Don't fret if this doesn't work right away, as this part will most likely need immediate tuning. Bring your palm to the front left or right corner of the robot. If the LED near that sensor lights up, you've been seen! If not, you most likely will have to tune it. Put your Sumovore down within 6" (15cm) of an object, like a book or tissue box. Turn the 20k multiturn trimpot on the front sensor board 20 turns to the left, then slowly turn it to the right, counting the rotations until you see the "opponent detected" LED come on. Remember that number, and keep turning the screw.

When the LED goes off, average that number and reset the trimpot to that value. This will be the most sensitive your Sumovore can be. Of course, being too sensitive can be bad, so feel free to "de-tune" your robot so it only detects object within 7 or 8 inches (19 to 21cm).

Tuning example: LED turns on at 5 turns, and turns off again at 12 turns. $(5 + 12) / 2 = 8.5$ turns. Start at the beginning, and turn 8.5 turns to get to maximum sensitivity.



Step 13: Install brainboard
Step 14: Install batteries



Step 15: Check for various blinky lights! (See text)



The Solarbotics Sumovore

Troubleshooting



Step 16: Installing the Wheels: No magic or mystery here, especially now that Solarbotics is manufacturing custom wheels to fit these gearmotors, with high-performance rubber tires molded right onto the wheel body. These are much better than the old-style "traction-band" solution. These won't dry out and crack, or peel off in the middle of competition - these are good tires.

Install the wheels onto the shaft of the gear motors and secure them with the remaining two #2 x 1/4" pointy screws. Now you can repeat the tests you did in step 15 with a live, moving Sumovore!



Troubleshooting

Hopefully this section will be totally disregarded, but if you're still reading, then you must have a Sumovore problem. Let's see what we can do to fix you up.

The first level of inspection is to carefully examine all your solder joints to make sure you have sufficient solder on each, and that they're all nice and shiny. About 70% of all failures we see are due to poor soldering so don't simply say "Uhh... my soldering is just fine - there must be a bad component!" Take the time to go over your connections again, even if you have to clip gear motor zip-ties and peel sticky tape apart. You can always get more zip-ties and use hot-glue for the motors if you really need to. If the basic soldering inspection didn't reveal any failures, then let's use a bit more analytical process to isolate the problem.

Red LED not coming on? If the red LED at the back isn't turning on, there is most likely a failure on the edge sensor circuit board, or there's a problem with power connections. Check for:

- Battery polarity & charge - are batteries all in the right-way around, and have a full charge?
- Battery pack connections are correct? Black wires go to square pads, remember?
- There is a set of battery connection points for each pack, so make sure each pack is wired to the right place.
- The IR LEDs and rear red LED are in the right way around? They won't light up if they're in backwards.
- Front edge sensor circuit board sitting on all 8 pins? It's easy to accidentally move 1 pin over so you're only connecting to 7.
- If you have a voltmeter, check the voltage at the rear of the mainboard near the power switch in the box labeled 'DIAG1'. You should measure 9 volts (the full battery voltage) between a round pad and a square pad when the power switch is on. If not, there's a bad power connection someplace...

Sumovore Spinning on the spot? First identify if one motor is dead, or spinning in reverse. If it's spinning, then the simple answer is to go back to the terminal blocks and reverse the connections for that motor. If the motor is dead, check for:

- Sufficient insulation stripped off wire going into terminal block. Bare wire has to be clamped in the block.
- Try manually spinning the motor with power off. If it's considerably hard than spinning the functional motor, you most likely have a shorted motor. Check the motor terminal tabs and make sure nothing is shorting against the metal motor body

Sumovore Suspiciously Slow? Check the L293D installation. It'll work backwards, but much slower than normal!

Edge Sensors ALWAYS Triggering? One or more of your QRD1114 edge sensors are in backwards! Look at the bottom of the sensors, and make sure they all look the same. If they don't all look identical, you've got some sensors in backwards - check the documentation again!

More troubleshooting answers on the next page...



The Solarbotics Sumovore

Troubleshooting (cont'd)



Sumovore not seeing the white edge line? Start with the front edge sensors board (good thing that sensor board is easily removable, eh?). The sensors are pretty good at detecting white, so leaving the trimpots in the middle position as a default is a good place to start. You'll only need to really mess with them when you're setting up for line-follower mode.

- One or more IR reflector sensors may be in backwards. Make sure they're ALL in the correct way around.
- The IR reflector sensors have a very short range, so if they're further than 1/4" (7mm) from the surface, they may not see the line. Pull the sensor board downward a bit on the pins and see if that makes a difference.
- Try tuning them to maximum sensitivity by turning the single-turn 10k trimpots on the corner fully clockwise.
- The IR reflector sensors are sensitive to infrared light, which means what you might think is reflective may not be to the sensors. Regular paper reflects IR well, as do your fingertips. Many white plastics look "transparent" to IR.
- The Sumovore needs the front IR circuit board to be installed to show any sign of life. If it isn't in properly or is installed backwards, nothing will happen!

Sumovore not seeing Opponents? It's time to watch those red LEDs!

- The rear red LED indicates that the IR transmitters are working. If there's no light, one (or both) of the clear IR LEDs may be in backwards, or the rear red LED is in backwards.
- If your rear red LED is on, but still no detecting is happening, make sure you've followed the IR transmit frequency tuning we discussed in "Building the Body - Step 17". Twiddle that 20k multiturn trimpot on the edge-detection board!
- Check the IR detectors are working by using any TV / VCR / DVD remote control. Point it at each IR detector on the top corners of the mainboard while pressing any button. Does the red LED right behind the detector blink? If yes, the problem lies with the IR transmitter. If no, then make sure you have the indicator LEDs installed the correct way and the solder connections are secure. If you have a multimeter, see if you can measure 5 volts between the middle and right pin of the IR receiver.
- If you're fortunate enough to have an oscilloscope or frequency-counting multimeter, try measuring the frequency at the points labeled "DIAG2 - 555 Output" on the edge-sensor board. You should see a nice square wave pattern, or a frequency count in the 30 to 60kHz range. Tune it to be between 34kHz and 42kHz for best performance.

There are Bite Marks on my Sumovore! Stop throwing it for your dog to catch. And keep your cat off your workbench.

I don't have enough traction! Try layering both traction bands onto your wheels for a softer tire. And clean them between matches with rubbing alcohol. And don't forget, you can "bulk up" your Sumovore to 500 grams for maximum traction!

My Startup timer is too Long/Short! Ah, that's easy to fix. See the trimpot on the top right side of your discrete brainboard? Turn it clockwise for longer delay; counter-clockwise for shorter.

My Sumovore is turning too Much/Not Enough when it sees the white line! Another easy fix. The two trimpots at the middle of the discrete brainboard each adjust the time the Sumovore spends backing up and turning when that side gets activated. If it's barely backing off and turning when the right edge sensor touches the line, then turn the middle-right trimpot more clockwise.

Line-follower mode sucks! Line-follower competitions require finesse and skillful tuning. Line follower mode uses the black line to turn off the motor on the side that detects the black line, which rotates the Sumovore back until the edge sensor no longer sees the black line. Here's the proper tuning procedure:

- 1) Turn both 10k single-turn trimpots full counter-clockwise.
- 2) Place your Sumovore on a white section of your line-follower track.
- 3) Slowly turn each pot clockwise until the motor on that same side activates.
- 4) Repeat for the other side

If you're going to be doing lots of line follower, you may want to take advantage of the holes on the front sensor plate near the edge, and mount a low-friction slider to make your Sumovore quicker and more maneuverable.

My Sumovore has edges sensors that are touchy and hard to tune! This is more common if you have a brighter-coloured front plate, like yellow or white. The IR light from the edge sensors is being reflected around by the backside of the plate causing false readings, so colour the backside of the front plate black to reduce these unwanted reflections.



The Solarbotics Sumovore



Version 1.1 Electronic Layout Diagram

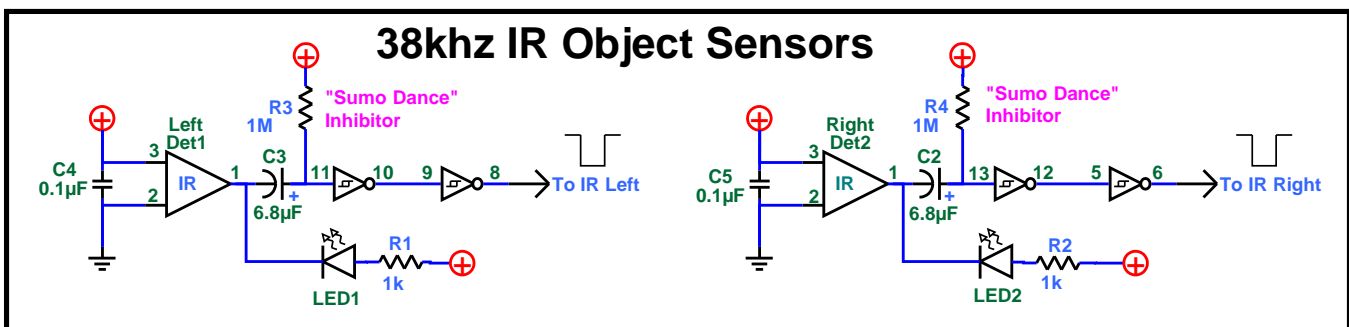
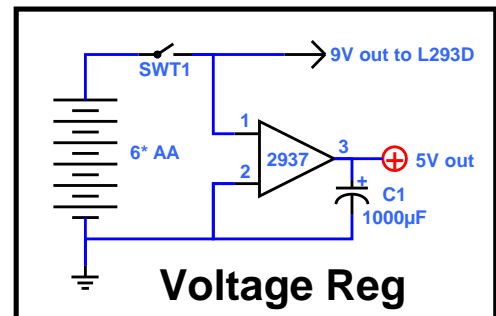
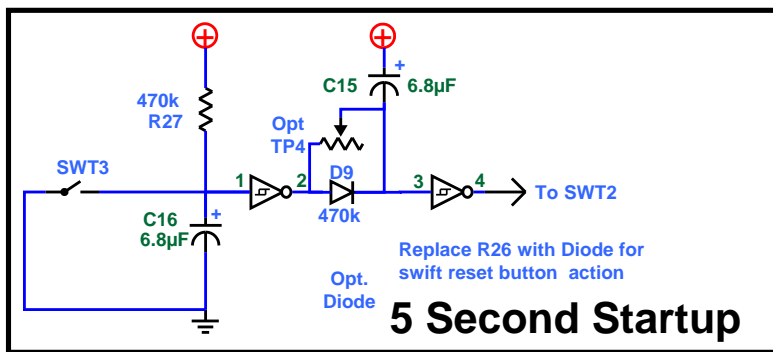
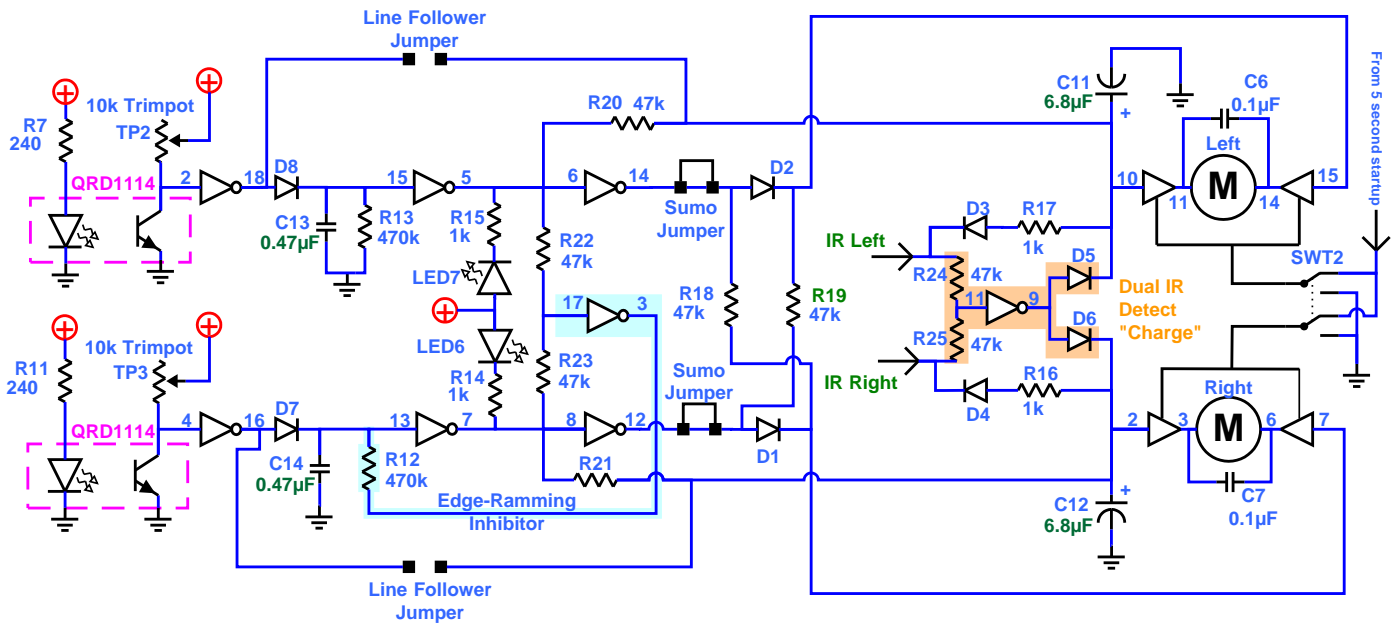
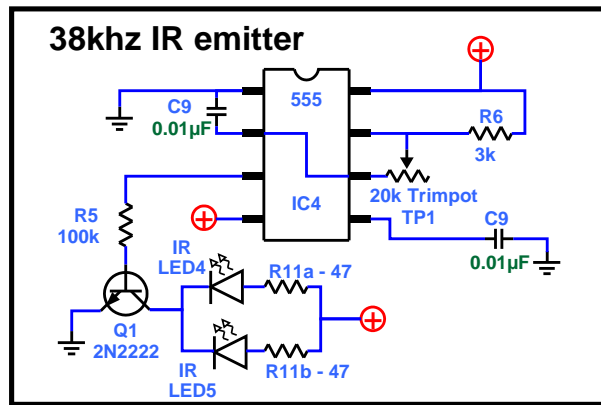



The Solarbotics Sumovore

Rear Sensor Option



Sumovore Rear Sensor Option: You may have noticed the spots at the rear center of the mainboard labeled 'Opt IR DET3' and 'Opt C8'. These are the mounting points for another PNA4602 IR sensor and 0.1µF filter capacitor. The idea is to install a rear-looking sensor, so it's less likely that you will be approached from behind and "escorted" out to the edge of the sumo ring. Installation is straightforward, simply mount these parts in the locations mentioned, but you'll most likely have to cut the lead lengths down as there will most likely be stuff in the way below. You're now half-way there!

So what do you have to do to finish getting all the way there? Well, it's one thing to detect an opponent behind you, but what are you going to do about it? We're going to use a positive detection trigger the same behaviour as if the opponent was detected by the left or right sensor. We'll run the output signal from the rear sensor to one of the front sensor outputs, so a rear-detection triggers the same response as a left or right detection.

Solder a wire from the pad just above the DET3 sensor position, and thread it through the one of the holes on the mainboard to up near where you wired up the 4AA battery holder. If you look closely, you'll see two pads labeled 'Right' and 'Left'. Pick a direction you want your Sumovore to turn when it detects a rear opponent, and solder your wire to that pad.

What you've finished now is a passive sensor, which is that it doesn't send out a signal to detect the opponent. It's depending on the opponent to broadcast a 38kHz IR signal (very common) for you to detect. Like a submarine just listening for its adversary.

If you want to be proactive and send out active "pings" to locate your opponent, you can install an IR emitter in parallel with the red indicator LED at the back. If you look at the bottom just below this LED, you'll see a second set of solder points where you can solder on an IR emitter. You can use another focused emitter like the front of your Sumovore, or use a wide-angle emitter like the OP140A shown in the picture - practically any IR emitter will do the job. Be aware that installing the extra emitter will most likely pull enough power away from the red LED that it won't light up anymore. If you wish, you can yank the red LED right out and install your IR emitter there instead - just make sure it doesn't poke out far enough to violate the 10 x 10cm maximum size rule. Be warned: - if your opponent is looking for a 38kHz signal, you've just put a big 'ol beacon for him to lock on to!

Step 1: Install Sensor, capacitor and one end of wire

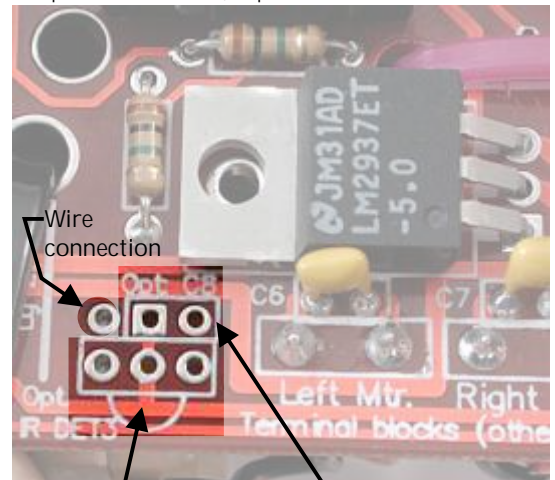

Step 2: Thread wire through to front right side

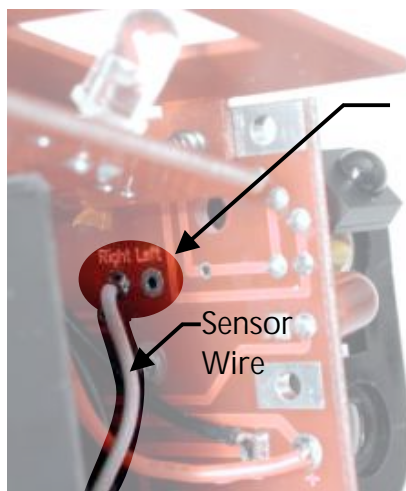

Step 3: Connect other end of wire to 'Right' or 'Left'



Step 4 (Opt.): Install IR Emitter below LED3



The Solarbotics Sumovore



Add-ons and Upgrades!

We've been saying all along that the Sumovore is a flexible minisumo platform - here's our proof!

If you want to make your Sumovore programmable with a PIC, replace the standard discrete-logic brain with the Microchip 16F877A brainboard add-on.
K SV-PIC \$25.95 USD/CAD



The ATmega8L-based Brainboard lets you program in practically any language, and download the code via a simple parallel-port cable!
K SV-Atmel \$20.95 USD/CAD



This module lets you interface your own BS2 compatible or Stamp Stack II module (not included) to your Sumovore.
K SV-BS2. \$15.95 USD/CAD



The 25030 HVWTech Stamp Stack II is a 100% compatible Basic Stamp 2 microcontroller, with added in features to make it beginner friendly.
25030. \$35.00 USD/CAD



The PICAXE will let you program by either using simple flowcharts or coding with a BASIC-like language. This system is beginner-friendly and flexible enough for advanced builders. Comes with a PICAXE 28X1 IC!
K SV-PICAXE. . . \$29.95 USD / \$34.95 CAD

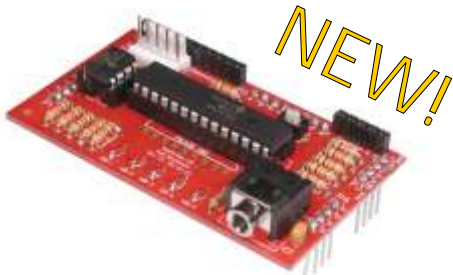

Triple the speed and double the torque with an RM2! Don't forget to make the necessary adjustments to your Sumovore! Maybe you blew a motor? We have replacement RM3's.
RM2. \$2.25 USD/CAD





The Solarbotics Sumovore

Mini-Sumo Competition Rules



There are a good many robot clubs and contests that run their own mini-sumo contests, and most adhere to the same rules. Here's a short list of the rules you can expect to see at these competitions.

The Robot

- Must not weigh more than 500 grams (1.1lb)
- Must fit in a 10cm (3.937in) by 10cm square but can be any height
- Sumo must not move for the first 5 seconds of match
- Sumo is allowed to expand after the 5 second startup
- No weapons! (i.e. Flamethrowers or Blades of Doom!)
- No damaging the ring! (i.e. Saw blade wheels or drilling holes)
- Tires must not be sticky
-

The Competition Platform Ring

- Ring has a 77cm diameter
- Ring is a flat black surface with a 2.5cm (1in) wide white ring around the perimeter
- There are two parallel starting lines with a width of 1cm a length of 10cm and are located 10cm apart from the center of the ring. These lines are brown so that they do not trigger any IR edge sensors.
- Ring is usually constructed with black melamine but some events use steel platforms
- Ring height is usually 2 inches for edge detecting robots, some competitions use a ring height of 1 inch

Running of the Competition

- You have to win two of three matches to win your bout
- Matches are a maximum of 3 minutes in length
- If it is agreed between both competitors the match may end earlier (i.e.: if both sumo cease to function)
- The higher-ranked sumo (or winner from previous match) is placed first on the ring and positioned. The lesser-ranked robot is then allowed to position.
- Upon the signal from the referee/judge, the robots are activated. No motion from the robot is allowed for five seconds upon activation. This allows competitors to get a safe distance away from the competition platform.
- North American rules state that you may position your robot to start anywhere behind in the zone extending from the starting line off to the left and right edges of the sumo ring.
- Japanese rules state that you may position your robot to start so that some portion of it is touching the zone extending directly backward from the ends of the starting line to the rear edge.

Want to discuss your Sumovore with other Sumovore owners? Visit our Yahoogroup at:
<http://groups.yahoo.com/group/Sumovore/>

Other Cool Projects from Solarbotics

Build some friends to keep your Sumovore company!

Herbie the Mousebot is a 9-volt battery-powered robot that loves to chase flash light beams. If there are several Herbies in the same area, they can be configured to chase each other! These little robots are so quick, you have to run to keep up to them!

K HM Herbie the Mousebot \$39.95 USD/CAD



Like the Mousebot, the *K PP Photopopper* seeks light and avoids obstacles but is solar powered! It's pretty quick, covering a meter per minute (that's 3.3 feet!). Newly upgraded with better electronics and gold circuit board!

K PP Photopopper \$45.00 USD/CAD

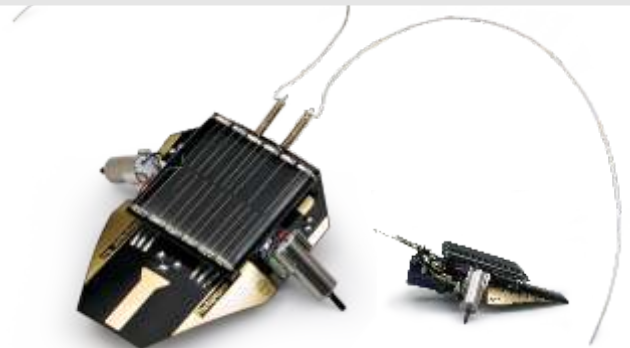

Perhaps something a bit more advanced?

The K BB-Proto makes use of the expansion port on the new "Version 2" brainboards for the Sumovore and ScoutWalker III. By simply plugging it in, it lets you tap three servo headers, raw 6V and regulated 5V power, transistor, RJ11 & IC footprints, and I2C taps.

K BB-Proto. \$4.95 USD/CAD

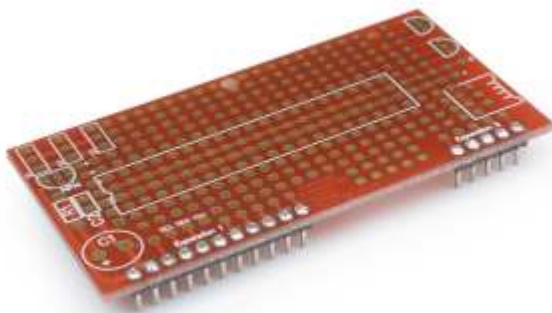

Being more capable, less expensive, and more expandable than any other two-motor walker design on the market makes this kit ideal for your walking robot experiments!

K W3 ScoutWalker III. . . \$89.95 USD/CAD

