

# QuadBot

4 legged robot chassis

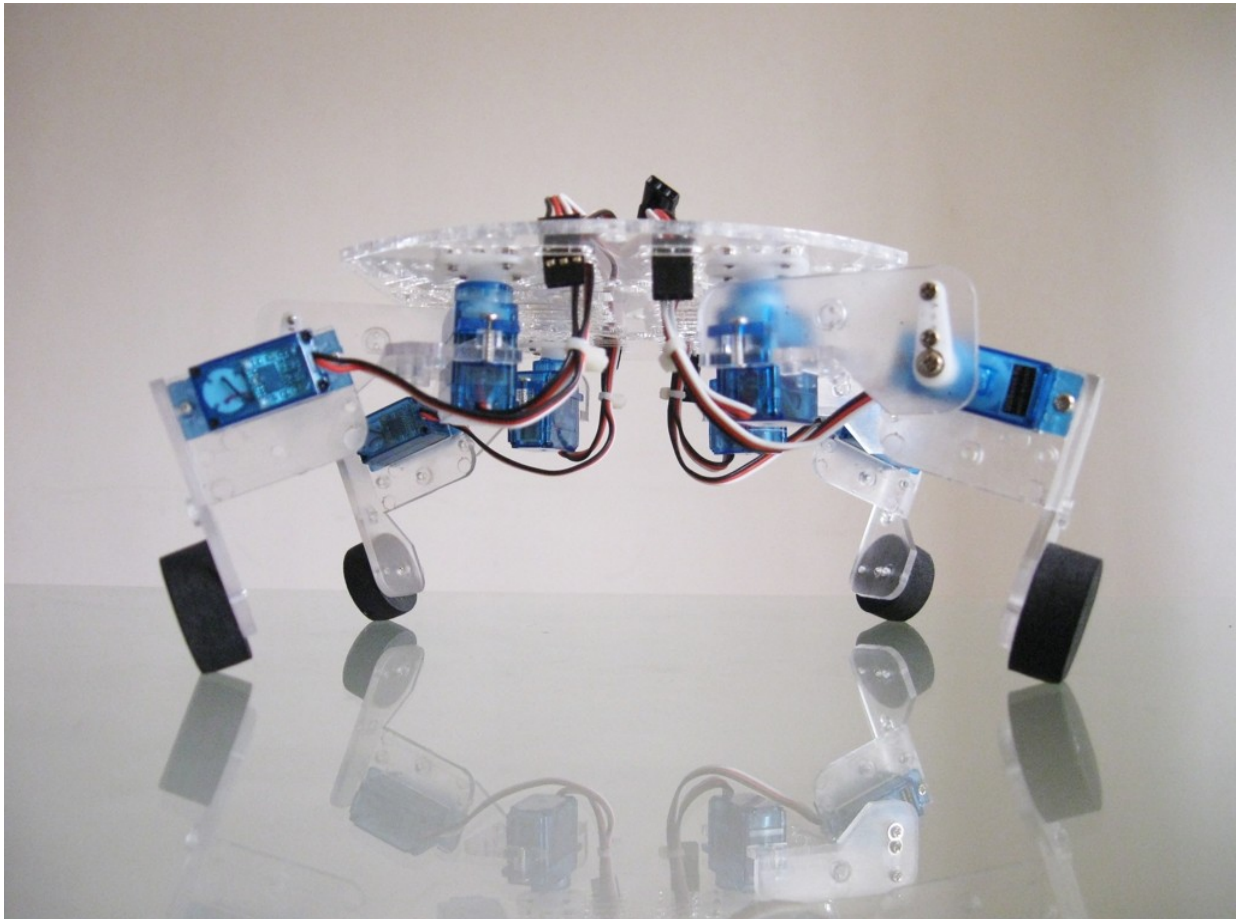

The QuadBot robot chassis is a lightweight, simple 4 legged robot chassis ideal for students and hobbyist wanting to experiment with walking robots.

Numerous holes and slots have been cut into the mounting plate allowing controllers and batteries to be easily mounted.

#### **The kit includes:**

- 1x laser cut acrylic mounting plate
- 4x foam rubber feet
- 8x leg segments
- 8x miniature servos
- 4x 3mm x 10mm pan head screws
- 8x 2mm x 6mm self tapping screws
- 8x 2mm x 8mm pan head screws
- 16x 2mm x 6mm pan head screws

#### **Servo Specifications:**

Weight: 8g  
Torque: 1.5Kg / cm @ 6V  
Speed: 0.1 sec / 60 degrees  
Max voltage: 6V  
Travel: 180 degrees

## Assembly instructions

### Step 1:

Mount the 4x foam rubber feet to leg segments as shown using 3mm x 12mm pan head screws.

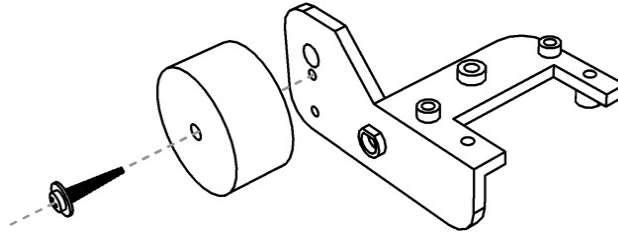

### Step 2:

Mount a servo on each of the leg segments fitted with a foot as shown using 2.3mm x 8mm self-tapping screws.

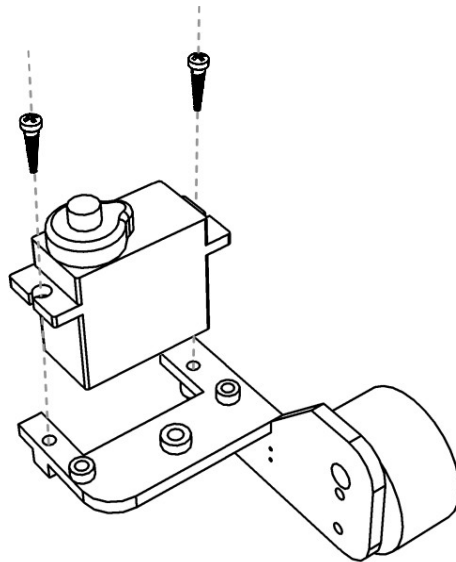

### Step 3:

Mount a servo horn to an unused leg segment as shown using 2mm x 6mm self-tapping screws. Center the servo and then fit the leg segment to the servo using a 2mm x 8mm pan head screw as shown. Gently turn the servo by hand to check the range of movement and adjust if necessary.

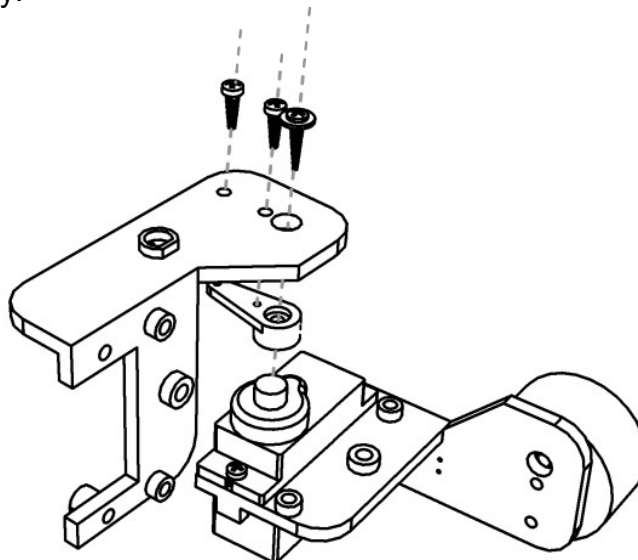

**Step 4:**

Now we must make two legs for the right side of the chassis. Mount two servos as shown in the diagram with 2.3mm x 8mm self-tapping screws. Note the orientation of the servo.

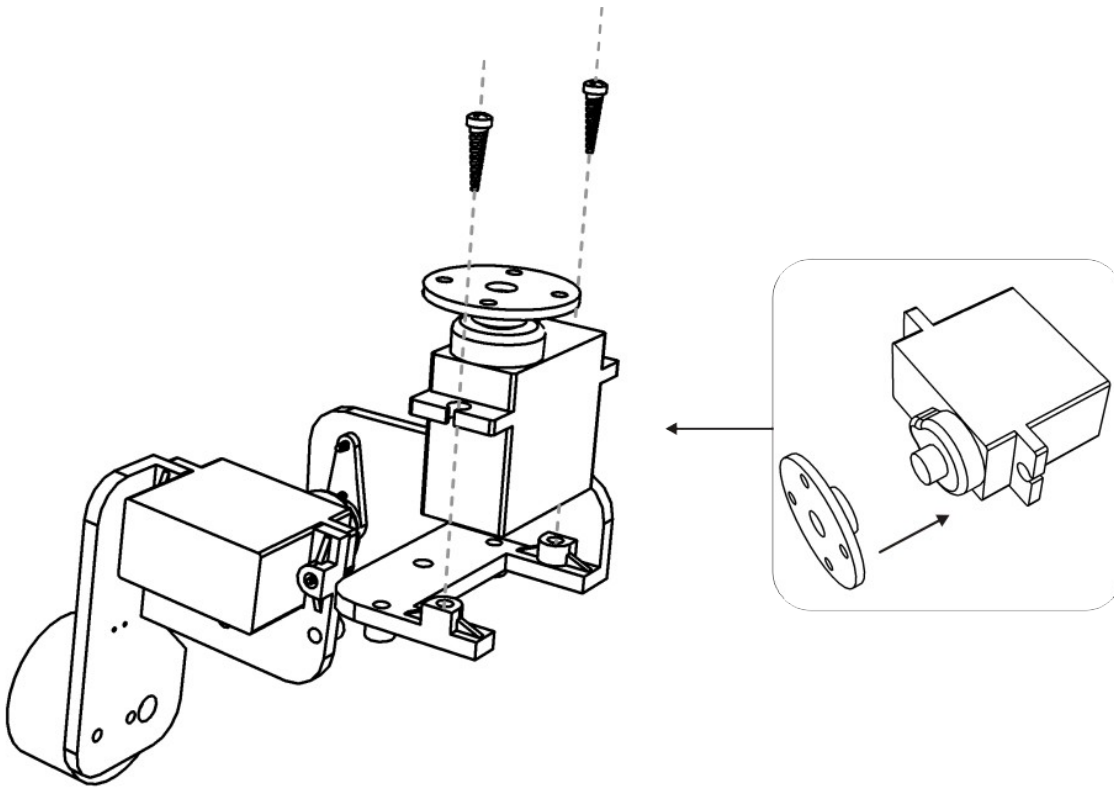

**Step 5:**

We make two legs for the left side of the robot in a similar manner to step 4 except that the servo is mounted the opposite way.

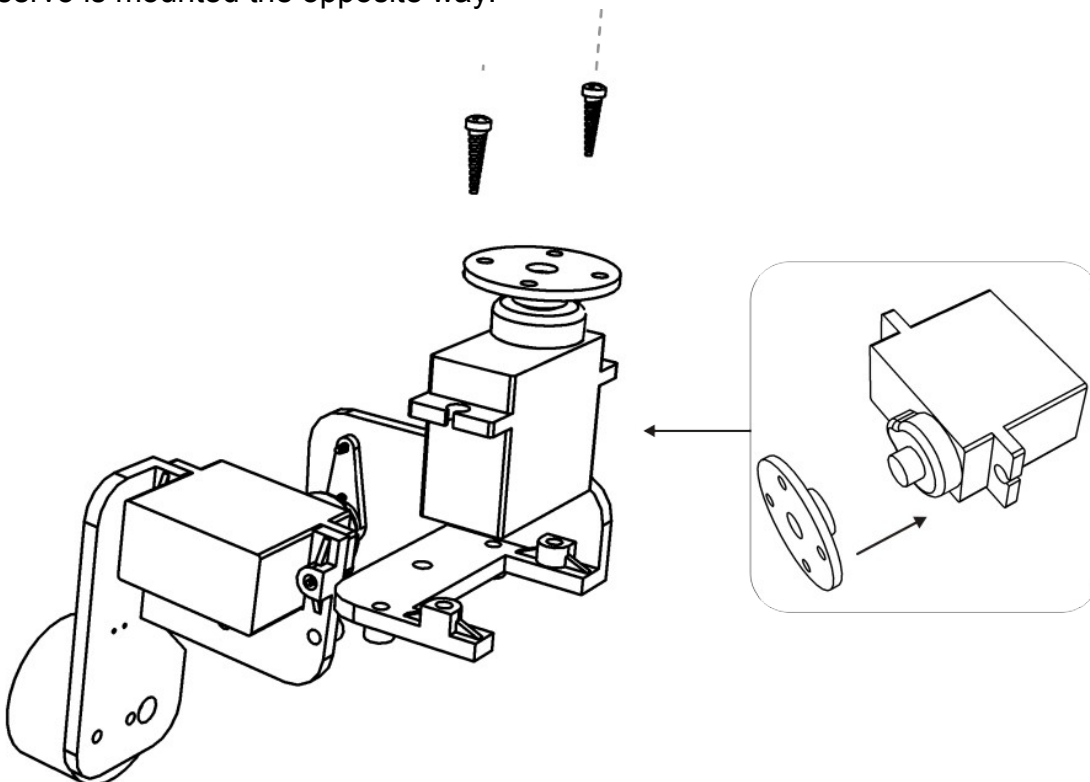

**Step 6:**

Center your servos and mount the legs onto the mounting plate using 2mm x 6mm pan head screws. Use a 2mm x 8mm pan head screw in the center of the servo horn to secure the servo to the mounting plate.

When mounting the servo horn to the mounting plate the holes marked in red are recommended. Gently move the legs by hand to check their range of movement and adjust the servo horns as required. Your chassis is now ready to use.

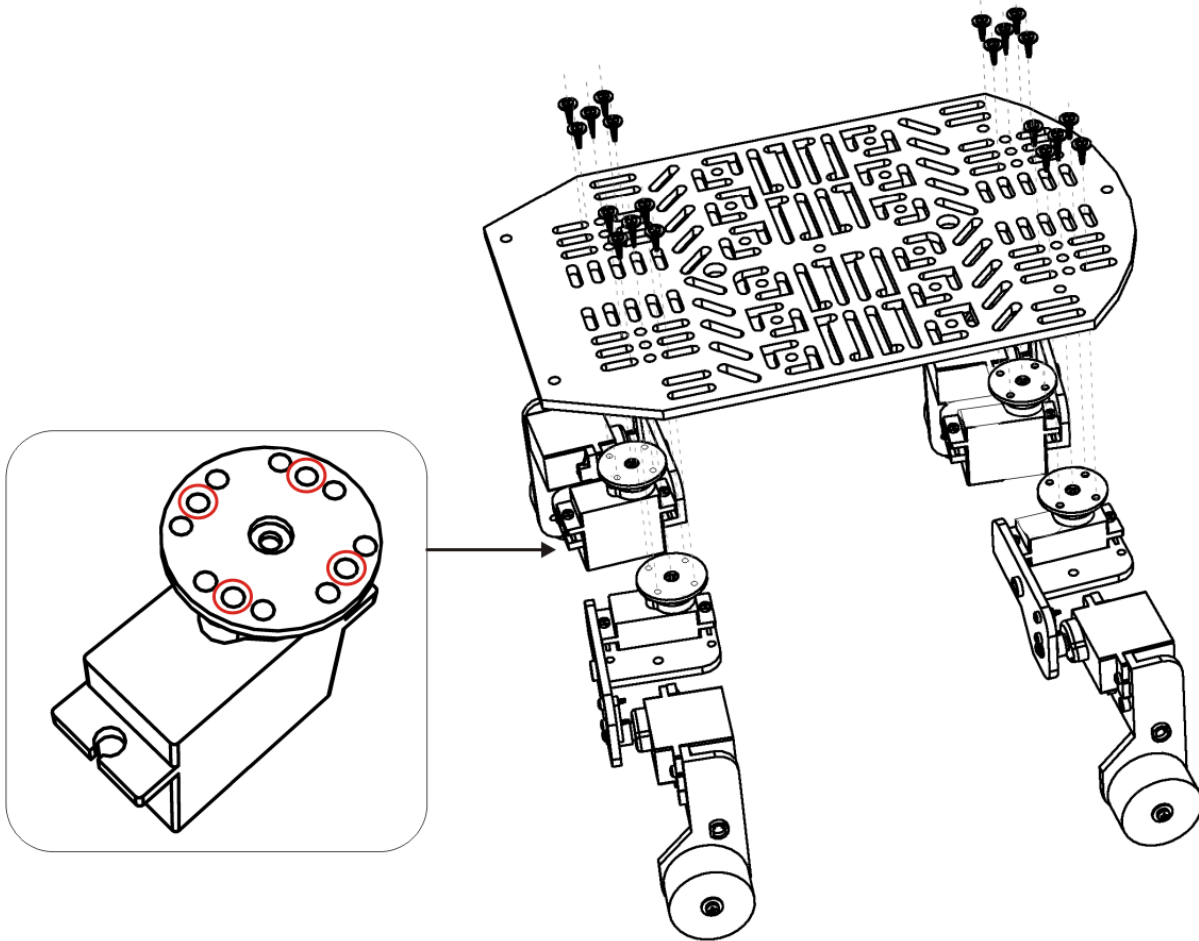
**Suggestions:**

Each leg segment has a mounting position for a 3mm LED molded into it. Adding LEDs to the legs makes the robot look better and less likely to be accidentally stood on.

Using lightweight batteries will allow the chassis to move quicker and reduce power consumption. AAA NiMh or LiPo batteries are recommended.

Fitting a small Force Sensing Resistor (FSR) to each foot and it will allow your robot to measure the weight on each foot. This will allow your robot to balance when climbing over rough surfaces.

